

JGT200HF120G2VH

IGBT Module

Preliminary Data

Features:

- Trench & Field Stop IGBT
- Short Circuit Rated > 10 μ s
- Low Switching Loss
- 100% RBSOA Tested (2xI_c)
- Low Stray Inductance
- Copper Wire Bonding on Power Terminal
- Lead Free, Compliant with RoHS Requirement

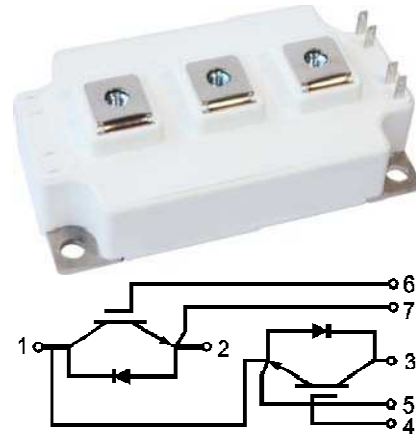

Applications:

- Welding
- HEV Inverter
- Industrial Motor Drives
- UPS

IGBT, Inverter

Maximum Rated Values(T_C=25°C unless otherwise specified)

| | | | | |
|------------------|------------------------------------|--------------------------|------|----|
| V _{CES} | Collector-Emitter Blocking Voltage | | 1200 | V |
| V _{GES} | Gate-Emitter Voltage | | ±20 | V |
| I _C | Continuous Collector Current | T _C =100°C | 200 | A |
| | | T _C =25°C | 400 | A |
| I _{CM} | Peak Collector Current Repetitive | T _J =175°C | 400 | A |
| t _{SC} | Short Circuit Withstand Time | | >10 | μs |
| P _D | Maximum Power Dissipation (IGBT) | T _C =25°C | 1440 | W |
| | | T _{Jmax} =175°C | | |

Electrical Characteristics of IGBT ($T_C=25^\circ\text{C}$ unless otherwise specified)

| Symbol | Description | Conditions | Min | Typ | Max | Unit | |
|---------------|--------------------------------------|--|-------------------------|------|------|------|---|
| $V_{GE(th)}$ | Gate-Emitter Threshold Voltage | $I_C=6\text{mA}$, $V_{CE}=V_{GE}$ | 5.0 | 5.7 | 6.8 | V | |
| $V_{CE(sat)}$ | Collector-Emitter Saturation Voltage | $I_C=200\text{A}$, $V_{GE}=15\text{V}$ | $T_J=25^\circ\text{C}$ | | 1.60 | | V |
| | | | $T_J=125^\circ\text{C}$ | | 1.80 | | V |
| | | | $T_J=150^\circ\text{C}$ | | 1.90 | | V |
| I_{CES} | Collector-Emitter Leakage Current | $V_{GE}=0\text{V}$, $V_{CE}=V_{CES}$, $T_J=25^\circ\text{C}$ | | | 1 | mA | |
| I_{GES} | Gate-Emitter Leakage Current | $V_{GE}=\pm 20\text{V}$, $V_{CE}=0\text{V}$, $T_J=25^\circ\text{C}$ | | | 400 | nA | |
| C_{ies} | Input Capacitance | $V_{CE}=25\text{V}$, $V_{GE}=0\text{V}$, $f=1\text{MHz}$ | | 16.6 | | nF | |
| C_{res} | Reverse Transfer Capacitance | | | 0.58 | | nF | |

Static Characteristics

Switching Characteristics

| | | | | | | | |
|--------------|------------------------|---|-------------------------|--|------|--|---------------|
| $t_{d(on)}$ | Turn-on Delay Time | $V_{CC}=600\text{V}$, $I_C=200\text{A}$, $R_{Gon}=1\Omega$, $V_{GE}=\pm 15\text{V}$, Inductive Load | $T_J=25^\circ\text{C}$ | | 0.31 | | μs |
| | | | $T_J=125^\circ\text{C}$ | | 0.31 | | |
| | | | $T_J=150^\circ\text{C}$ | | 0.31 | | |
| t_r | Rise Time | $V_{CC}=600\text{V}$, $I_C=200\text{A}$, $R_{Goff}=1\Omega$, $V_{GE}=\pm 15\text{V}$, Inductive Load | $T_J=25^\circ\text{C}$ | | 0.10 | | μs |
| | | | $T_J=125^\circ\text{C}$ | | 0.11 | | |
| | | | $T_J=150^\circ\text{C}$ | | 0.11 | | |
| $t_{d(off)}$ | Turn-off Delay Time | $V_{CC}=600\text{V}$, $I_C=200\text{A}$, $R_{Goff}=1\Omega$, $V_{GE}=\pm 15\text{V}$, Inductive Load | $T_J=25^\circ\text{C}$ | | 0.31 | | μs |
| | | | $T_J=125^\circ\text{C}$ | | 0.33 | | |
| | | | $T_J=150^\circ\text{C}$ | | 0.34 | | |
| t_f | Fall Time | $V_{CC}=600\text{V}$, $I_C=200\text{A}$, $R_{Goff}=1\Omega$, $V_{GE}=\pm 15\text{V}$, Inductive Load | $T_J=25^\circ\text{C}$ | | 0.18 | | μs |
| | | | $T_J=125^\circ\text{C}$ | | 0.32 | | |
| | | | $T_J=150^\circ\text{C}$ | | 0.34 | | |
| E_{on} | Turn-on Switching Loss | $V_{CC}=600\text{V}$, $I_C=200\text{A}$, $R_{Gon}=1\Omega$, $V_{GE}=\pm 15\text{V}$, $di/dt=1620\text{A}/\mu\text{s}$ ($T_J=150^\circ\text{C}$) Inductive Load | $T_J=25^\circ\text{C}$ | | 14.7 | | mJ |
| | | | $T_J=125^\circ\text{C}$ | | 18.9 | | |
| | | | $T_J=150^\circ\text{C}$ | | 20.2 | | |

| | | | | | |
|-------------------------|--|---|-----------------------|-------|-------|
| E _{off} | Turn-off Switching Loss | V _{CC} =600V, I _C =200A, R _{Goff} =1Ω, V _{GE} = ±15V, du/dt=3120V/μs (T _J =150°C) Inductive Load | T _J =25°C | 15.7 | mJ |
| | | | T _J =125°C | 22.7 | |
| | | | T _J =150°C | 24.7 | |
| Q _g | Total Gate Charge | V _{GE} =+15V...-15V | T _J =25°C | 1.07 | μC |
| R _{g internal} | Internal Gate Resistance | | T _J =25°C | 3.75 | Ω |
| RBSO A | I _C =400A, V _{CC} =1050V, V _p =1200V, R _{Goff} =2Ω, V _{GE} =+15V to 0V, T _J =150°C | Trapezoid | | | |
| I _{sc} | SC Data | V _{CC} = 600V, V _{GE} = ± 15V, tp=10us R _{G on} =6.8Ω, R _{Goff} = 6.8Ω, T _J = 150°C | | 994 | A |
| R _{θJC} | IGBT Thermal Resistance: Junction-To-Case(per leg) | | | 0.104 | °C /W |

Maximum Rated Values of Diode (T_C=25°C unless otherwise specified)

| | | | |
|------------------|----------------------------------|------|---|
| V _{RRM} | Repetitive Peak Reverse Voltage | 1200 | V |
| I _F | Diode Continuous Forward Current | 200 | A |
| I _{FM} | Diode Maximum Forward Current | 400 | A |

Electrical Characteristics of Diode (T_C=25°C unless otherwise specified)

| Symbol | Description | Conditions | Min | Typ | Max | Unit |
|-----------------|-------------------------------|---|-----------------------|------|-----|------|
| V _{FM} | Forward Voltage | I _F =200A | T _J =25°C | 1.6 | | V |
| | | | T _J =125°C | 1.7 | | |
| | | | T _J =150°C | 1.7 | | |
| t _{rr} | Reverse Recovery Time | I _F =200A, -diF/dt=1855A/μs(T _J =150°C), V _R =600V, V _{GE} =-15V | T _J =25°C | 0.32 | | μs |
| | | | T _J =125°C | 0.53 | | |
| | | | T _J =150°C | 0.56 | | |
| I _{rr} | Peak Reverse Recovery Current | I _F =200A, -diF/dt=1855A/μs(T _J =150°C), V _R =600V, V _{GE} =-15V | T _J =25°C | 128 | | A |
| | | | T _J =125°C | 144 | | |
| | | | T _J =150°C | 150 | | |

| | | | | | | | |
|------------------|--|---|-----------------------|--|-------|--|-------|
| Q _{rr} | Reverse Recovery Charge | I _F =200A, -diF/dt=1855A/μs(T _J =150°C), V _R =600V, V _{GE} =-15V | T _J =25°C | | 20.7 | | μC |
| | | | T _J =125°C | | 34.5 | | |
| | | | T _J =150°C | | 38.8 | | |
| E _{rec} | Reverse Recovery Energy | | T _J =25°C | | 8.5 | | mJ |
| | | | T _J =125°C | | 14.1 | | |
| | | | T _J =150°C | | 16.5 | | |
| R _{θJC} | Diode Thermal Resistance: Junction-To-Case (per leg) | | | | 0.166 | | °C /W |

Module

| Symbol | Description | | Min | Typ | Max | Unit |
|------------------|--|------------------|------|------|------|------|
| V _{iso} | Isolation Voltage (All Terminals Shorted) | f =50Hz, 1minute | 2500 | | | V |
| T _J | Maximum Junction Temperature | | | | 175 | °C |
| T _{JOP} | Maximum Operating Junction Temperature Range | | -40 | | +150 | °C |
| T _{stg} | Storage Temperature | | -40 | | +125 | °C |
| CTI | Comparative Tracking Index | | 200 | | | |
| R _{θCS} | Case-To-Sink Thermally (Conductive Grease Applied) | | | 0.03 | | °C/W |
| M | Power Terminals Screw:M6 | | 3.0 | | 5.0 | N·m |
| M | Mounting Screw:M6 | | 4.0 | | 6.0 | N·m |
| G | Weight | | | 300 | | g |

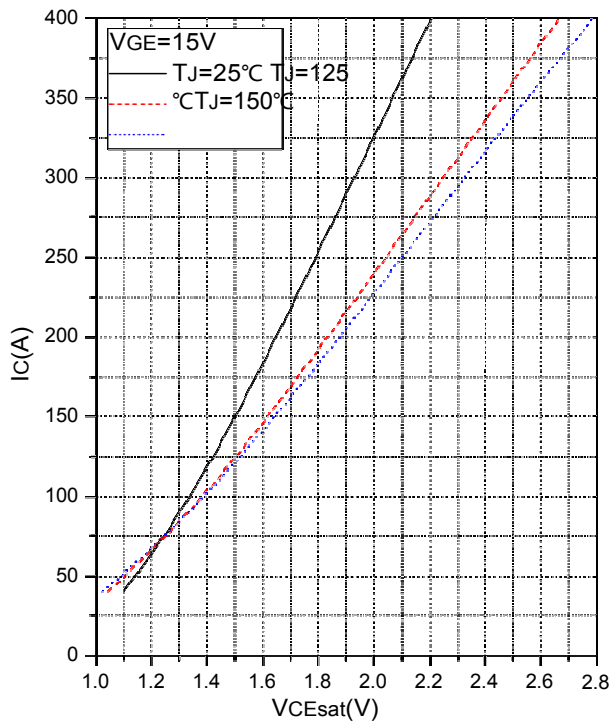

Fig.1 Typical Saturation Voltage Characteristics

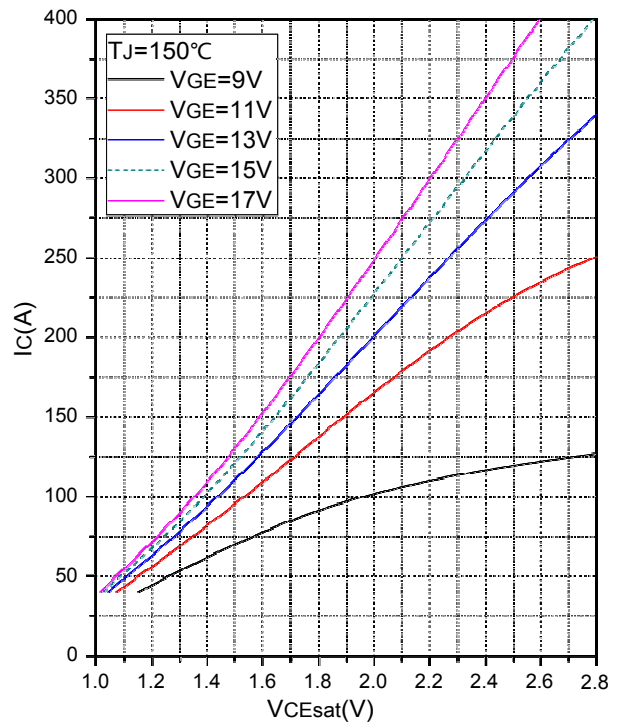

Fig.2 Typical Output Characteristics

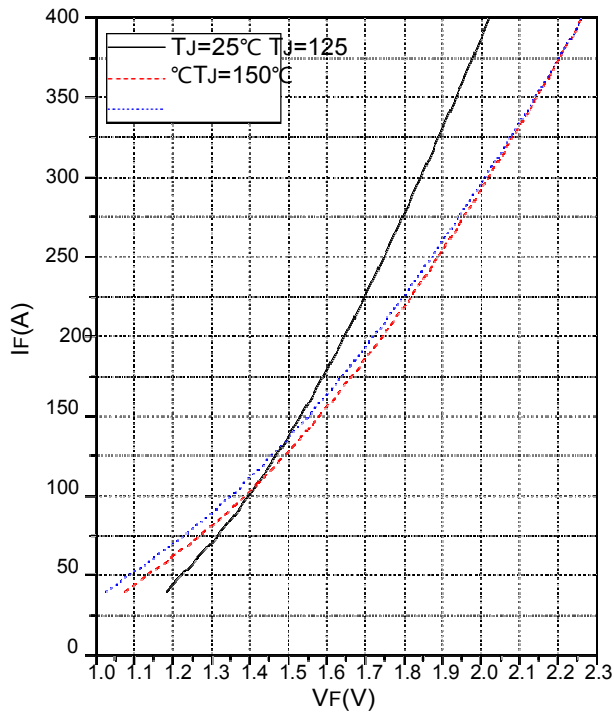

Fig.3 Forward Characteristics of Diode

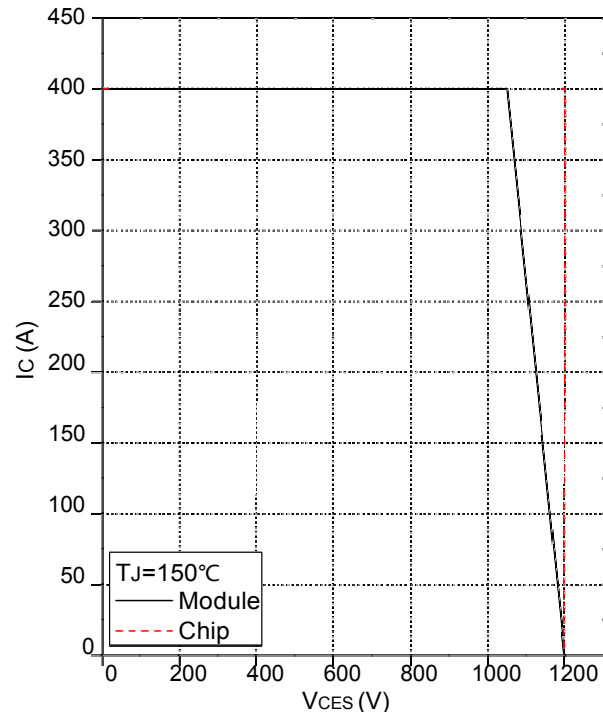

Fig.4 Reverse Bias Safe Operation Area (RBSOA)

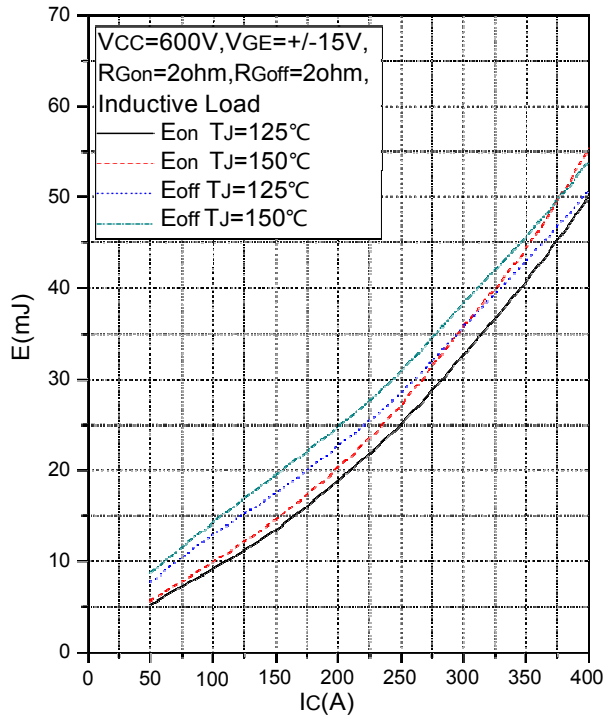

Fig.5 Typical Switching Loss vs. Collector Current

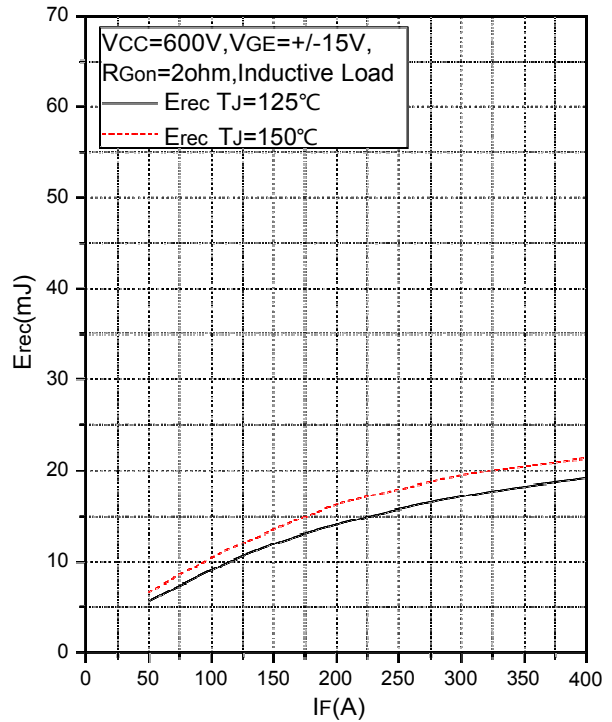

Fig.6 Typical Switching Loss vs. Gate Resistance

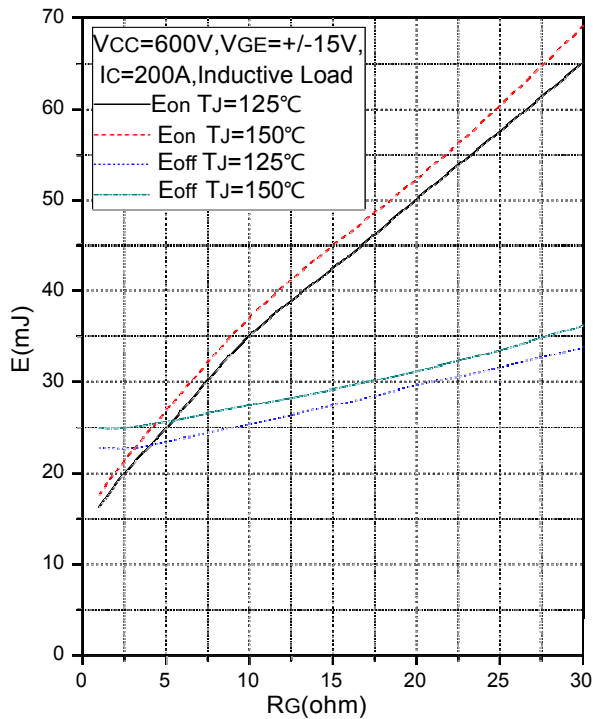

Fig.7 Typical Switching Loss vs. Forward Current

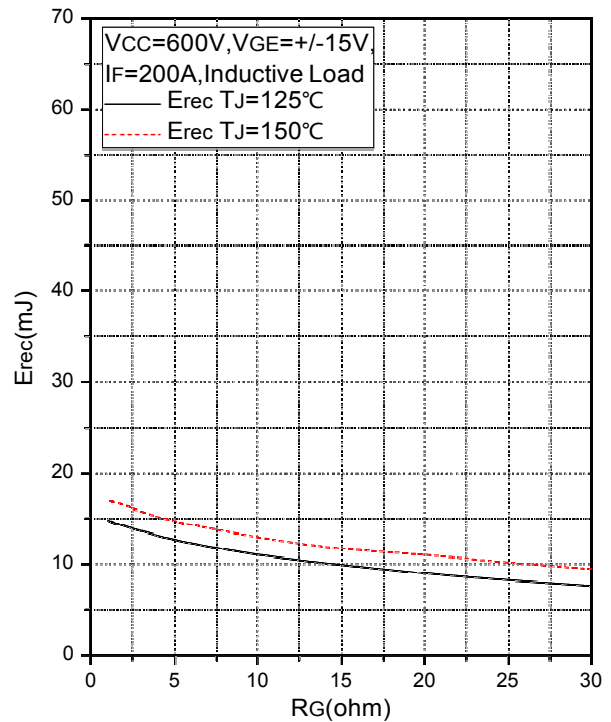

Fig.8 Typical Switching Loss vs. Gate Resistance

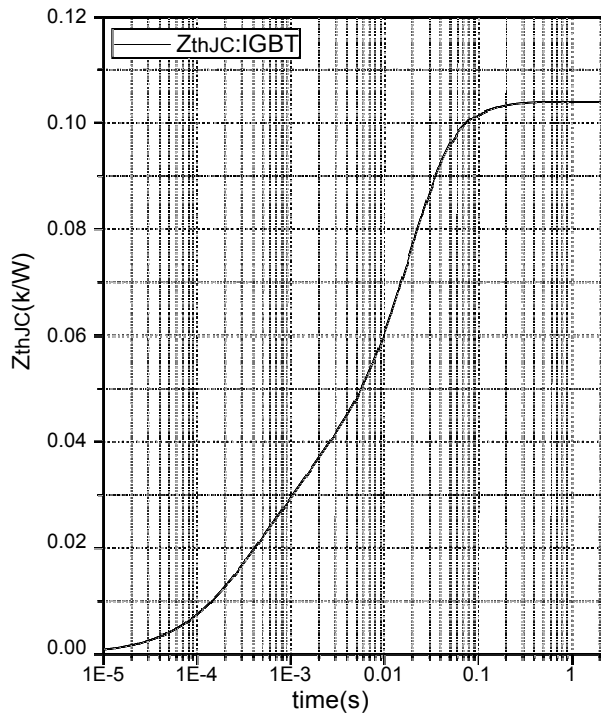

Fig.9 Transient Thermal Impedance (IGBT)

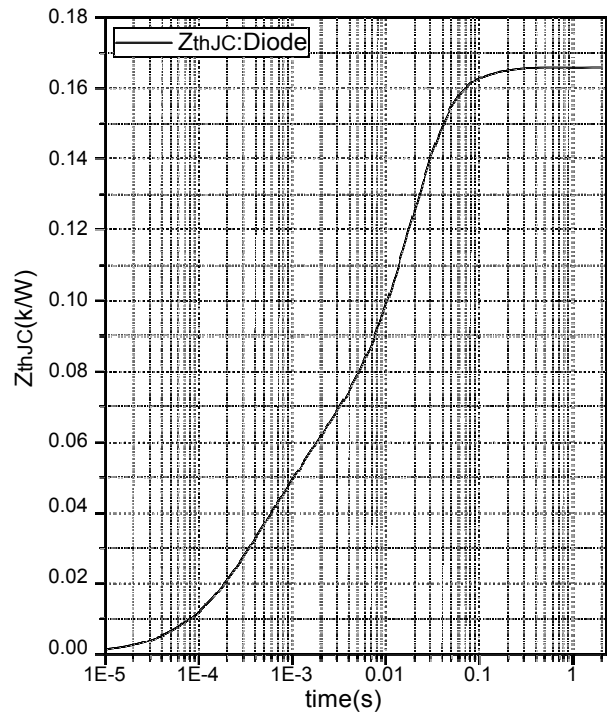
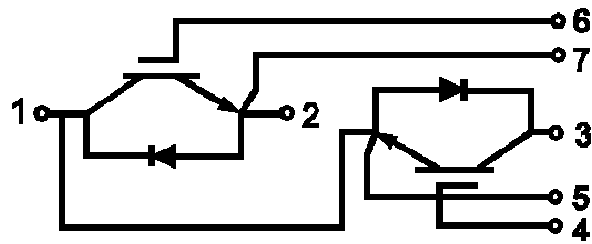
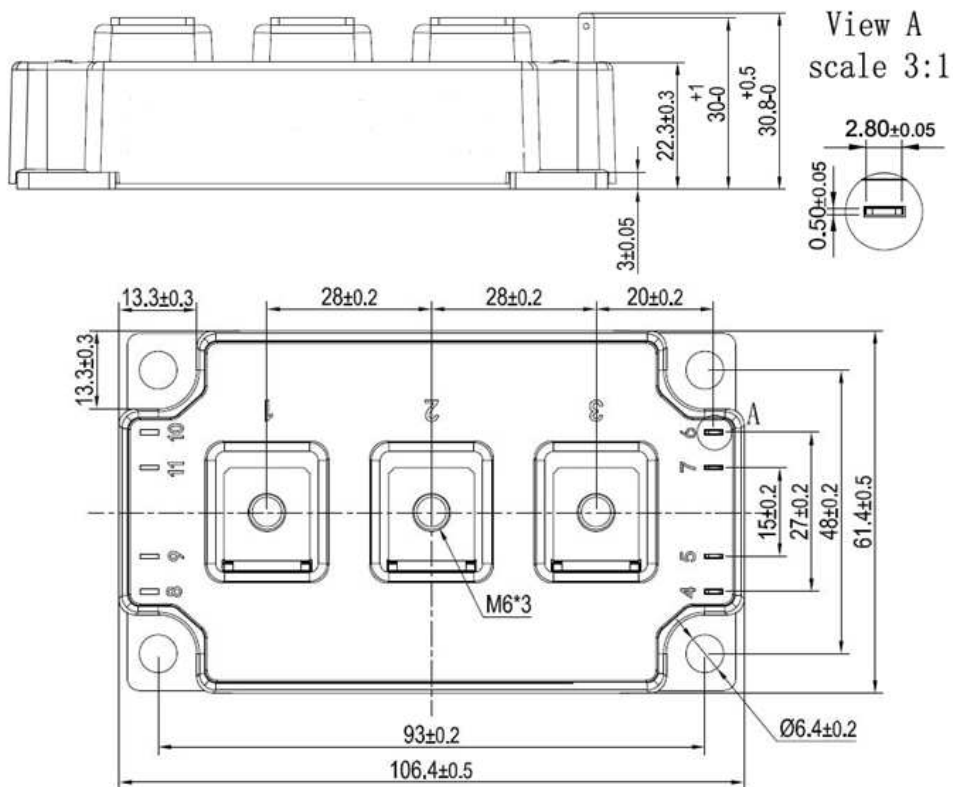

Fig.10 Transient Thermal Impedance (Diode)

Internal Circuit



Package Outline (Unit: mm):





| Date | Revision | Notes |
|------------|----------|-----------------|
| 07/18/2022 | 01 | Initial Release |