



POWER SEMICONDUCTOR
PRODUCT GUIDE

Dynex Semiconductor has a rich history in the design, development and production of High Power Semiconductors and Power Assemblies.

Our products throughout the years have been applied in projects that vary from Traction, Power Quality through HVDC, Renewable Energy production, to helping science advance.

Contents

IGBT Modules	02
1200V IGBT Modules	
Choppers, Dual Switches and Single Switches	04
1700V IGBT Modules	
Bi-directional Switches, Choppers, Dual Switches, Half Bridges and Single Switches	04
3300V IGBT Modules	
Choppers, Dual Switches, Half Bridges and Single Switches	05
4500V IGBT Modules	
Choppers, Single Switches	07
6500V IGBT Modules	
Choppers, Single switches	07
FRD Modules	08
1200V FRD Modules	
Dual Diodes and Triple Diodes	10
1800V FRD Modules	
Dual Diodes and Triple Diodes	10
3300V FRD Modules	
Dual Diodes, Triple Diodes and Series Pair Diodes	10
4500V and 6500V FRD Modules	
Dual Diodes and Triple Diodes	11
Bipolar Thyristors and Diodes	12
Phase Control Thyristors	14-15
Asymmetric Bypass Thyristor	16
Pulsed Power Thyristors	17
Rectifier Diodes	18-19
Fast Recovery Diodes	19
Package Outlines	20
IGBT Modules	21-22
FRD Modules	23
Thyristors and Diodes	24
GTO	25
Power Assemblies	26
Overview including Assemblies, AC Switches, Heatsinks and Sub-contract Partnerships	28-29
Symbols and Definitions	30
Important Information	32

A close-up, low-angle photograph of an IGBT (Insulated-Gate Bipolar Transistor) module. The module is dark grey or black, featuring several prominent, silver-colored cooling fins that are slightly curved. On the left side, there are several terminal bolts, some of which are secured with blue plastic caps. The background is a dark blue gradient with faint, concentric circular lines, suggesting a technical or industrial setting. The overall lighting is dramatic, highlighting the metallic textures and the complex geometry of the module.

IGBT Modules

1200V IGBT Modules

Part Number	Configuration	Production Status	I _c (A)	at T _c (°C)	V _{CE(sat)} @ T _c =25°C (V)	Total E _{sw} @ T _c =125°C (mJ)	R _{th(j-c)} (per switch) (°C/kW)	Baseplate Dims (mm)	Isolation Voltage	Tech
AISiC Baseplate										
DIM2400ESM12-A	Single	MP	2400	85	2.2	800	6	190 x 140	2.5 kV	DNPT
DIM1800ESM12-A	Single	MP	1800	85	2.2	570	8	190 x 140	2.5 kV	DNPT
DIM1600FSM12-A	Single	MP	1600	85	2.2	500	9	140 x 130	2.5 kV	DNPT
DIM1200FSM12-A	Single	MP	1200	85	2.2	400	12	140 x 130	2.5 kV	DNPT
DIM800FSM12-A	Single	MP	800	85	2.2	280	18	140 x 130	2.5 kV	DNPT
DIM800DDM12-A	Dual	MP	800	85	2.2	280	18	140 x 130	2.5 kV	DNPT
DIM600DDM12-A	Dual	MP	600	85	2.2	200	24	140 x 130	2.5 kV	DNPT
DIM400DDM12-A	Dual	MP	400	85	2.2	120	36	140 x 130	2.5 kV	DNPT
DIM800DCM12-A	Chopper	MP	800	85	2.2	280	18	140 x 130	2.5 kV	DNPT
Copper Baseplate										
DIM2400ESS12-A	Single	MP	2400	85	2.2	800	6	190 x 140	2.5 kV	DNPT
DIM1800ESS12-A	Single	MP	1800	85	2.2	570	8	190 x 140	2.5 kV	DNPT
DIM1600FSS12-A	Single	MP	1600	85	2.2	500	9	140 x 130	2.5 kV	DNPT
DIM1200FSS12-A	Single	MP	1200	85	2.2	400	12	140 x 130	2.5 kV	DNPT
DIM800FSS12-A	Single	MP	800	85	2.2	280	18	140 x 130	2.5 kV	DNPT
DIM800DDS12-A	Dual	MP	800	85	2.2	280	18	140 x 130	2.5 kV	DNPT
DIM600DDS12-A	Dual	MP	600	85	2.2	200	24	140 x 130	2.5 kV	DNPT
DIM400DDS12-A	Dual	MP	400	85	2.2	120	36	140 x 130	2.5 kV	DNPT
DIM800DCS12-A	Chopper	MP	800	85	2.2	280	18	140 x 130	2.5 kV	DNPT

1700V IGBT Modules

Part Number	Configuration	Production Status	I _c (A)	at T _c (°C)	V _{CE(sat)} @ T _c =25°C (V)	Total E _{sw} @ T _c =125°C (mJ)	R _{th(j-c)} (per switch) (°C/kW)	Baseplate Dims (mm)	Isolation Voltage	Tech
DNPT Range										
DIM2400ESM17-A	Single	MP	2400	75	2.7	1950	6	190 x 140	4 kV	DNPT
DIM1600FSM17-A	Single	MP	1600	75	2.7	1250	9	140 x 130	4 kV	DNPT
DIM1200FSM17-A	Single	MP	1200	75	2.7	1000	12	140 x 130	4 kV	DNPT
DIM800FSM17-A	Single	MP	800	75	2.7	700	18	140 x 130	4 kV	DNPT
DIM800DDM17-A	Dual	MP	800	75	2.7	700	18	140 x 130	4 kV	DNPT
DIM600DDM17-A	Dual	MP	600	75	2.7	620	24	140 x 130	4 kV	DNPT
DIM400DDM17-A	Dual	MP	400	75	2.7	350	36	140 x 130	4 kV	DNPT
DIM1600ECM17-A	Chopper	MP	1600	75	2.7	1250	9	190 x 140	4 kV	DNPT
DIM800DCM17-A	Chopper	MP	800	75	2.7	785	18	140 x 130	4 kV	DNPT
DIM600DCM17-A	Chopper	MP	600	75	2.7	620	24	140 x 130	4 kV	DNPT
DIM400DCM17-A	Chopper	MP	400	75	2.7	350	36	140 x 130	4 kV	DNPT
DIM400PHM17-A	Half Bridge	MP	400	75	2.7	350	36	140 x 73	4 kV	DNPT
DIM400PBM17-A	Bi-directional	MP	400	75	4.9*	350	36	140 x 73	4 kV	DNPT

* V_{CE(sat)} is measured across both arms of the bi-directional switch.

MP: Mass Production NEW: New Products NRND: Not Recommended for New Design

3300V IGBT Modules

Part Number	Configuration	Production Status	I _c (A)	at T _c (°C)	V _{CE(sat)} @ T _c =25°C (V)	Total E _{sw} @ T _c =125°C (mJ)	R _{th(j-c)} (per switch) (°C/kW)	Baseplate Dims (mm)	Isolation Voltage	Tech
d² TS Range (standard)										
DIM1500ESM33-TS	Single	MP	1500	110	2.2	5750	8	190 x 140	6 kV	d ²
DIM1500ASM33-TS001	Single	MP	1500	110	2.2	5750	8	190 x 140	10.2 kV	d ²
DIM1000NSM33-TS	Single	MP	1000	110	2.2	3900	12	140 x 130	6 kV	d ²
DIM1000XSM33-TS001	Single	MP	1000	110	2.2	3900	12	140 x 130	10.2 kV	d ²
DIM500GDM33-TS	Dual	MP	500	110	2.2	1950	24	140 x 130	6 kV	d ²
DIM1000ECM33-TS	Chopper	MP	1000	110	2.2	3900	12	190 x 140	6 kV	d ²
DIM1000ACM33-TS001	Chopper	MP	1000	110	2.2	4150	12	190 x 140	10.2 kV	d ²
DIM500GCM33-TS	Chopper	MP	500	110	2.2	1950	24	140 x 130	6 kV	d ²
DIM250PKM33-TS	Chopper	MP	250	110	2.2	960	48	140 x 73	6 kV	d ²
DIM250PLM33-TS	Chopper	MP	250	110	2.2	960	48	140 x 73	6 kV	d ²
DIM250PHM33-TS	Half Bridge	MP	250	110	2.2	960	48	140 x 73	6 kV	d ²
d² TL Range (low loss)										
DIM1500ESM33-TL	Single	NEW	1500	115	2.0	7150	8	190 x 140	6 kV	d ²
DIM1500ASM33-TL001	Single	NEW	1500	115	2.0	7150	8	190 x 140	10.2 kV	d ²
DIM1000NSM33-TL	Single	NEW	1000	115	2.0	4750	12	140 x 130	6 kV	d ²
DIM1000XSM33-TL001	Single	NEW	1000	115	2.0	4750	12	140 x 130	10.2 kV	d ²
DIM500GDM33-TL	Dual	NEW	500	115	2.0	2400	24	140 x 130	6 kV	d ²
DIM1000ECM33-TL	Chopper	NEW	1000	115	2.0	4750	12	190 x 140	6 kV	d ²
DIM1000ACM33-TL001	Chopper	NEW	1000	115	2.0	4750	12	190 x 140	10.2 kV	d ²
DIM500GCM33-TL	Chopper	NEW	500	115	2.0	2400	24	140 x 130	6 kV	d ²
DIM250PKM33-TL	Chopper	NEW	250	115	2.0	1200	48	140 x 73	6 kV	d ²
DIM250PLM33-TL	Chopper	NEW	250	115	2.0	1200	48	140 x 73	6 kV	d ²
DIM250PHM33-TL	Half Bridge	NEW	250	115	2.0	1200	48	140 x 73	6 kV	d ²
DSPT Range										
DIM1200ESM33-F	Single Switch	MP	1200	90	2.8	4400	8	190 x 140	6 kV	DSPT
DIM800NSM33-F	Single Switch	MP	800	90	2.8	2950	12	140 x 130	6 kV	DSPT
DIM800XSM33-F	Single Switch	MP	800	90	2.8	2950	12	140 x 130	10.2 kV	DSPT
DIM400NSM33-F	Single Switch	MP	400	90	2.8	1470	24	140 x 130	6 kV	DSPT
DIM400GDM33-F	Dual Switch	MP	400	90	2.8	1470	24	140 x 130	6 kV	DSPT
DIM800ECM33-F	Chopper	MP	800	90	2.8	2950	12	190 x 140	6 kV	DSPT
DIM400GCM33-F	Chopper	MP	400	90	2.8	1470	24	140 x 130	6 kV	DSPT
DIM400XCM33-F	Chopper	MP	400	90	2.8	1470	24	140 x 130	10.2 kV	DSPT
DIM200PLM33-F	Chopper	MP	200	90	2.8	655	48	140 x 73	6 kV	DSPT
DIM200PKM33-F	Chopper	MP	200	90	2.8	655	48	140 x 73	6 kV	DSPT
DIM200PHM33-F	Half Bridge	MP	200	90	2.8	655	48	140 x 73	6 kV	DSPT
DIM100PHM33-F	Half Bridge	MP	100	90	2.8	335	96	140 x 73	6 kV	DSPT

Custom IGBT Modules

Enhancing our range of power semiconductor devices, DYNEX Semiconductor Ltd has the capability to design, develop and manufacture custom IGBT modules.

Applications for power electronics devices often involve harsh operating conditions or environments necessitating devices capable of meeting these requirements.

DYNEX semiconductor utilises our vast experience in the manufacture of power semiconductors to design and produce high reliability IGBT modules customised to meet the individual demands for end applications including those in the aerospace, automotive, medical, renewable energy & traction markets.

DYNEX capabilities can encompass the following:

- Laser welded assemblies
- Ultrasonic Welding processes
- Copper Wire bonds
- Various die technologies (Trench gate, SiC..)
- Liquid cooled heatsinks
- Customised busbar arrangements
- Silver Sintering
- Customised packaging (case materials)
- Hermetic sealed packages

Using our experience in design of IGBT modules, Dynex has designed and manufactured modules that have helped our customers:

- Reduce system cost,
- Reduce total system size & weight
- Improve thermal characteristics
- Maximise system efficiency
- Operate in severe environments

Using our in-house design team, Dynex continues to develop own processes and designs to utilise the latest techniques to improve cooling, current output, lifetime and reliability.

Through initial concept to full production, Dynex will support your requirements to provide enhanced, reliable device outlines to meet your stringent demands.

For more information on how Dynex can help with your custom IGBT needs, please email contactus@dynexsemi.com

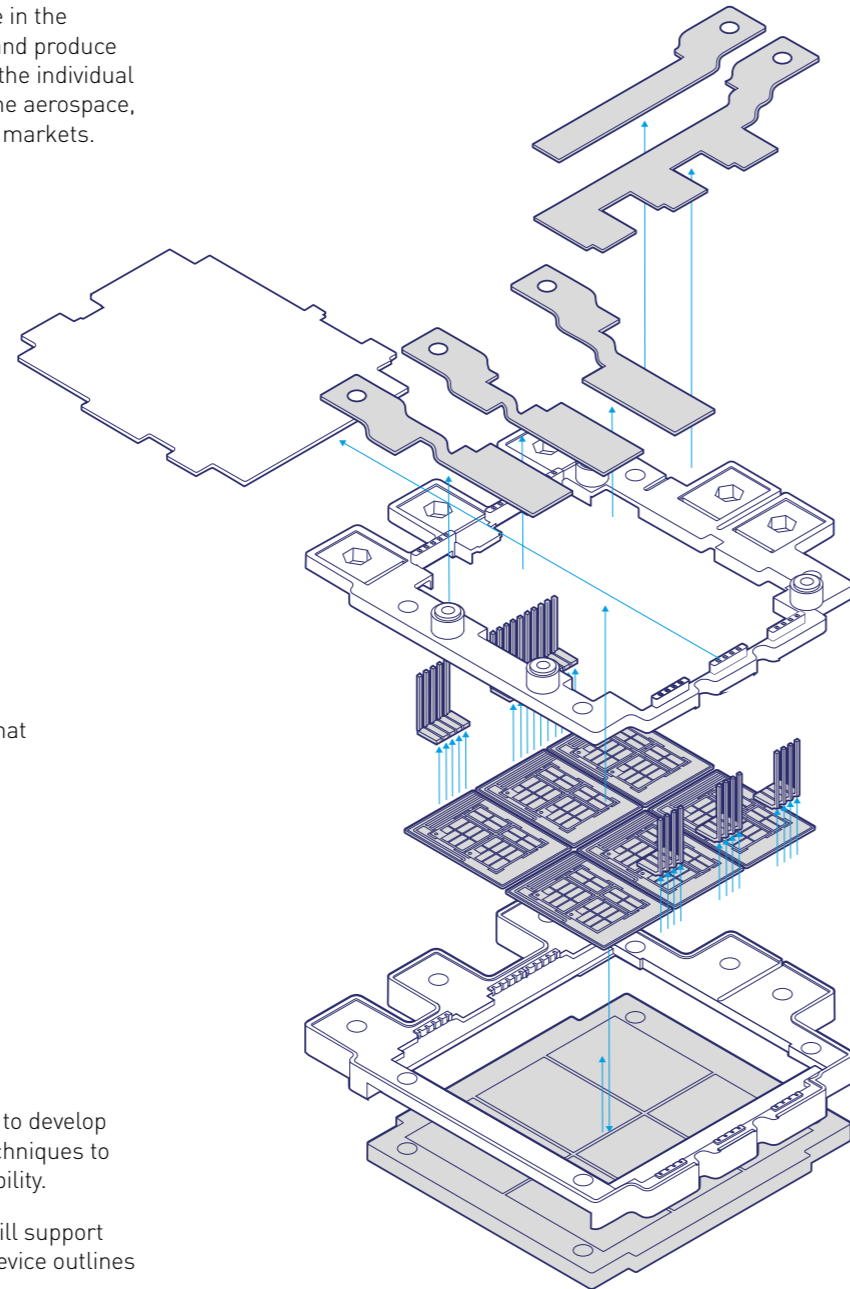

4500V IGBT Modules

Part Number	Configuration	Production Status	I _c (A)	at T _c (°C)	V _{CE(sat)} @ T _c =25°C (V)	Total E _{sw} @ T _c =125°C (mJ)	R _{th(j-c)} (per switch) (°C/kW)	Baseplate Dims (mm)	Isolation Voltage	Tech
-------------	---------------	-------------------	--------------------	------------------------	---	--	---	---------------------	-------------------	------

d² TS Range (standard)

DIM1200ASM45-TS	Single	NEW	1200	90	2.7	12000	8	190 x 140	7.4 kV	d ²
DIM1200ASM45-TS001	Single	NEW	1200	90	2.7	12000	8	190 x 140	10.2 kV	d ²
DIM1200ASM45-TL000	Single	NEW	1200	90	2.3	11650	8	190 x 140	7.4 kV	d ²
DIM800XSM45-TS	Single	NEW	800	90	2.7	7400	12	140 x 130	7.4 kV	d ²
DIM800XSM45-TS001	Single	NEW	800	90	2.7	7400	12	140 x 130	10.2 kV	d ²
DIM400XCM45-TS	Chopper	NEW	400	90	2.7	3800	24	140 x 130	7.4 kV	d ²
DIM400XCM45-TS001	Chopper	NEW	400	90	2.7	3800	24	140 x 130	10.2 kV	d ²
DIM400XSM45-TS	Single	NEW	400	90	2.7	3800	24	140 x 130	7.4 kV	d ²
DIM400XSM45-TS001	Single	NEW	400	90	2.7	3800	24	140 x 130	10.2 kV	d ²

d² TL Range (low loss)

DIM1200ASM45-TL	Single	NEW	1200	90	2.3	13650	8	190 x 140	7.4 kV	d ²
DIM1200ASM45-TL001	Single	NEW	1200	90	2.3	13650	8	190 x 140	10.2 kV	d ²
DIM800XSM45-TL	Single	NEW	800	90	2.3	9100	12	140 x 130	7.4 kV	d ²
DIM800XSM45-TL001	Single	NEW	800	90	2.3	9100	12	140 x 130	10.2 kV	d ²

6500V IGBT Modules

Part Number	Configuration	Production Status	I _c (A)	at T _c (°C)	V _{CE(sat)} @ T _c =25°C (V)	Total E _{sw} @ T _c =125°C (mJ)	R _{th(j-c)} (per switch) (°C/kW)	Baseplate Dims (mm)	Isolation Voltage	Tech
-------------	---------------	-------------------	--------------------	------------------------	---	--	---	---------------------	-------------------	------

d² Range

DIM750ASM65-TS	Single	NEW	750	90	3.0	10300	8	190 x 140	10.2 kV	d ²
DIM500XSM65-TS	Single	NEW	500	90	3.0	7000	12	140 x 130	10.2 kV	d ²
DIM500ACM65-TS	Chopper	NEW	500	90	3.0	7000	12	190 x 140	10.2 kV	d ²
DIM250XCM65-TS	Chopper	NEW	250	90	3.0	3500	24	140 x 130	10.2 kV	d ²

A close-up, low-angle photograph of several FRD (Fast Recovery Diode) modules. The modules are dark grey or black, with a prominent cooling fin structure on the left side. Each module has a silver-colored metal terminal on top, secured with a screw. The background is a dark blue gradient with faint, glowing blue lines that suggest a technical or industrial environment. The text 'FRD Modules' is overlaid on the right side of the image.

FRD Modules

1200V FRD Modules

Part Number	Configuration	Production Status	I _F (A per arm)	at T _C (°C)	Baseplate Dims (mm)	Isolation Voltage	I _F (A as single diode with external connection)	V _{f@T_{vj}} =25 °C	I ² t (kA ² s)	Q _{rr@T_{vj}}	E _{rec@T_{vj}}	R _{th(j-c)} (per arm) (°C/kW)
-------------	---------------	-------------------	----------------------------	------------------------	---------------------	-------------------	---	--------------------------------------	--------------------------------------	--------------------------------	---------------------------------	--

AISiC Baseplate

DFM1200EXM12-A	Triple Diode	MP	1200	75	190 x 140	2.5 kV	3600	1.9	200	300	140	20
DFM1200FXM12-A	Dual Diode	MP	1200	75	140 x 130	2.5 kV	2400	1.9	200	300	140	20
DFM900FXM12-A	Dual Diode	MP	900	75	140 x 130	2.5 kV	1800	1.9	150	225	105	27
DFM600FXM12-A	Dual Diode	MP	600	75	140 x 130	2.5 kV	1200	1.9	100	150	70	40

Copper Baseplate

DFM1200EXS12-A	Triple Diode	MP	1200	75	190 x 140	2.5 kV	3600	1.9	200	300	140	20
DFM1200FXS12-A	Dual Diode	MP	1200	75	140 x 130	2.5 kV	2400	1.9	200	300	140	20
DFM900FXS12-A	Dual Diode	MP	900	75	140 x 130	2.5 kV	1800	1.9	150	225	105	27
DFM600FXS12-A	Dual Diode	MP	600	75	140 x 130	2.5 kV	1200	1.9	100	150	70	40

1800V FRD Modules

Part Number	Configuration	Production Status	I _F (A per arm)	at T _C (°C)	Baseplate Dims (mm)	Isolation Voltage	I _F (A as single diode with external connection)	V _{f@T_{vj}} =25 °C	I ² t (kA ² s)	Q _{rr@T_{vj}}	E _{rec@T_{vj}}	R _{th(j-c)} (per arm) (°C/kW)
-------------	---------------	-------------------	----------------------------	------------------------	---------------------	-------------------	---	--------------------------------------	--------------------------------------	--------------------------------	---------------------------------	--

AISiC Baseplate

DFM1200EXM18-A	Triple Diode	MP	1200	75	190 x 140	4 kV	3600	2.0	480	540	360	20
DFM1200FXM18-A	Dual Diode	MP	1200	75	140 x 130	4 kV	2400	2.0	480	540	360	20
DFM900FXM18-A	Dual Diode	MP	900	75	140 x 130	4 kV	1800	2.0	270	410	270	27
DFM600FXM18-A	Dual Diode	MP	600	75	140 x 130	4 kV	1200	2.0	120	160	120	40

3300V FRD Modules

Part Number	Configuration	Production Status	I _F (A per arm)	at T _C (°C)	Baseplate Dims (mm)	Isolation Voltage	I _F (A as single diode with external connection)	V _{f@T_{vj}} =25 °C	I ² t (kA ² s)	Q _{rr@T_{vj}}	E _{rec@T_{vj}}	R _{th(j-c)} (per arm) (°C/kW)
-------------	---------------	-------------------	----------------------------	------------------------	---------------------	-------------------	---	--------------------------------------	--------------------------------------	--------------------------------	---------------------------------	--

TS Range

DFM1000EXM33-TS	Triple Diode	MP	1000	90	190 x 140	6 kV	3000	2.4	320	1070	1300	24
DFM1000NXM33-TS	Dual Diode	MP	1000	90	140 x 130	6 kV	2000	2.4	320	1070	1300	24
DFM500NXM33-TS	Dual Diode	MP	500	90	140 x 130	6 kV	1000	2.4	80	540	650	48
DFM250PXM33-TS	Series Pair	MP	250	90	140 x 73	6 kV	N/A	2.4	20	270	330	96

F Range (fast)

DFM1200NXM33-F	Dual Diode	MP	1200	70	140 x 130	6 kV	2400	2.9	720	900	900	16
DFM800NXM33-F	Dual Diode	MP	800	70	140 x 130	6 kV	1600	2.9	320	600	600	24
DFM400NXM33-F	Dual Diode	MP	400	70	140 x 130	6 kV	800	2.9	80	300	300	48
DFM400PXM33-F	Series Diode Pair	MP	400	70	140 x 73	6 kV	N/A	2.9	80	300	300	48
DFM200PXM33-F	Series Diode Pair	MP	200	70	140 x 73	6 kV	N/A	2.9	20	125	130	96
DFM100PXM33-F	Series Diode Pair	MP	100	70	140 x 73	6 kV	N/A	2.9	5	65	65	192

Notes:

* Refer to datasheets for T_{vj} max values
www.dynexsemi.com/product-area/frd-modules

4500V FRD Modules

Part Number	Configuration	Production Status	I _F (A per arm)	at T _C (°C)	Baseplate Dims (mm)	Isolation Voltage	I _F (A as single diode with external connection)	V _{f@T_{vj}} =25 °C	I ² t (kA ² s)	Q _{rr@T_{vj}}	E _{rec@T_{vj}}	R _{th(j-c)} (per arm) (°C/kW)
-------------	---------------	-------------------	----------------------------	------------------------	---------------------	-------------------	---	--------------------------------------	--------------------------------------	--------------------------------	---------------------------------	--

TS Range

DFM1200AXM45-TS	Triple Diode	NEW	1200	65	190 x 140	7.4 kV	3600	2.8	460	2200	4000	16
DFM1200AXM45-TS001	Triple Diode	NEW	1200	65	190 x 140	10.2 kV	3600	2.8	460	2200	4000	16
DFM1200XXM45-TS	Dual Diode	NEW	1200	65	140 x 130	7.4 kV	2400	2.8	460	2200	4000	16
DFM1200XXM45-TS001	Dual Diode	NEW	1200	65	140 x 130	10.2 kV	2400	2.8	460	2200	4000	16
DFM800XXM45-TS	Dual Diode	NEW	800	65	140 x 130	7.4 kV	1600	2.8	300	1450	2700	24
DFM800XXM45-TS001	Dual Diode	NEW	800	65	140 x 130	10.2 kV	1600	2.8	300	1450	2700	24
DFM400XXM45-TS	Dual Diode	NEW	400	65	140 x 130	7.4 kV	800	2.8	150	750	1350	48
DFM400XXM45-TS001	Dual Diode	NEW	400	65	140 x 130	10.2 kV	800	2.8	150	750	1350	48

F Range

DFM900NXM45-F000	Dual Diode	NRND	900	80	140 x 130	6kV	1800	3.0	432	1300	1600	16
DFM600NXM45-F000	Dual Diode	NRND	600	80	140 x 130	6kV	1200	3.0	192	850	1050	24
DFM600XXM45-F000	Dual Diode	NRND	600	80	140 x 130	10.2kV	1200	3.0	192	850	1050	24
DFM450NXM45-F000	Dual Diode	NRND	450	80	140 x 130	6kV	900	3.0	108	650	800	32

6500V FRD Modules

Part Number	Configuration	Production Status	I _F (A per arm)	at T _C (°C)	Baseplate Dims (mm)	Isolation Voltage	I _F (A as single diode with external connection)	V _{f@T_{vj}} =25 °C	I ² t (kA ² s)	Q _{rr@T_{vj}}	E _{rec@T_{vj}}	R _{th(j-c)} (per arm) (°C/kW)
-------------	---------------	-------------------	----------------------------	------------------------	---------------------	-------------------	---	--------------------------------------	--------------------------------------	--------------------------------	---------------------------------	--

TS Range

DFM750AXM65-TS	Triple Diode	NEW	750	70	190 x 140	10.2 kV	2250	3.8	218	1500	3000	20
DFM500XXM65-TS	Dual Diode	NEW	500	70	140 x 130	10.2 kV	1000	3.8	97	1000	2000	30
DFM250XXM65-TS	Dual Diode	NEW	250	70	140 x 130	10.2 kV	500	3.8	24	500	1000	60

The image shows a close-up, overlapping view of several circular semiconductor wafers. Each wafer is covered with intricate, light-colored circuit patterns, likely made of metal or conductive paste, which are used for manufacturing integrated circuits. The wafers are held together by a red frame or support structure. The background is a dark blue gradient with subtle, concentric circular patterns, suggesting a microscopic or high-tech environment.

Bipolar Thyristors and Diodes

Phase Control Thyristors

Phase Control Thyristors

Part Number	V _{DRM} (V)	V _{RRM} (V)	I _T (A) at T _C = 60°C (A)	I _{TSM} at T _{vj} V _R = 0 (kA)	dV/dt (V/μs)	Non Rep. di/dt (A/μs)	R _{th(j-c)} (°C/W)	Outline Type Code	Flange OD Contact OD Height (mm)	Clamping Force (kN) min - max
Up to 1400V										
DCR470T14	1400	1400	470	6.3	1000	1000	0.08	T	42/19/13.5	4-6
DCR780E14	1400	1400	780	9.1	1000	1000	0.041	E	42/25/14.5	4-6
DCR950D14	1400	1400	950	12.8	1000	1000	0.035	D	47/29/14.5	8-12
DCR1010G14	1400	1400	1010	15	1000	1000	0.035	G	58/35/26.5	12-18
DCR1910F14	1400	1400	1910	26	1000	1000	0.02	F	75/47/26.5	18-26
DCR2150X14	1400	1400	2150	29	1000	1000	0.018	X	85/53/26.5	26-34
DCR2980C14	1400	1400	2980	47	1000	1000	0.0125	C	100/63/26.5	40-50
DCR3710V14	1400	1400	3710	60	1000	1000	0.01	V	110/73/26.5	50-62
Up to 1800V										
DCR370T18	1800	1800	370	5	1000	1000	0.08	T	42/19/13.5	4-6
DCR720E18	1800	1800	720	8.3	1000	1000	0.041	E	42/25/14.5	4-6
DCR860D18	1800	1800	860	11.5	1000	1000	0.035	D	47/29/14.5	8-12
DCR960G18	1800	1800	960	14	1000	1000	0.035	G	58/35/26.5	12-18
DCR1710F18	1800	1800	1710	25	1000	1000	0.02	F	75/47/26.5	18-26
DCR1800F18	1800	1800	1800	32	1000	1000	0.02	F	75/47/26.5	18-26
DCR1970X18	1800	1800	1970	28	1000	1000	0.018	X	85/53/26.5	26-34
DCR2830C18	1800	1800	2830	45	1000	1000	0.0125	C	100/63/26.5	40-50
DCR3400V18	1800	1800	3400	60	1000	1000	0.01	V	110/73/26.5	50-62
Up to 2400V										
DCR4440W22	2200	2200	4440	64.5	1000	1000	0.007	W	120/84/26.5	62-78
DCR5900A22	2200	2200	5900	80	1000	1000	0.0057	A	150/100/35	74-91
DCR6430M22	2200	2200	6430	80	1000	1000	0.005	M	150/100/26.5	80-100
DCR590E24	2400	2400	590	7.8	1000	1000	0.041	E	42/25/14.5	4-6
DCR750D24	2400	2400	750	10	1000	1000	0.035	D	47/29/14.5	8-12
DCR1700X24	2400	2400	1700	23	1000	1000	0.018	X	85/53/26.5	26-34
DCR2360C24	2400	2400	2360	35	1000	1000	0.0125	C	100/63/26.5	40-50
DCR3060V24	2400	2400	3060	45	1000	1000	0.01	V	110/73/26.5	50-62
Up to 3000V										
DCR850G26	2600	2600	850	11	1000	1000	0.035	G	58/35/26.5	12-18
DCR1560F26	2600	2600	1560	24	1000	1000	0.02	F	75/47/26.5	18-26
DCR7610H28	2800	2800	7610	105	1000	1000	0.004	H	172/110/35	110-130
DCR2060C28	2800	2800	2060	30	1000	1000	0.0125	C	100/63/26.5	40-50
DCR2760V28	2800	2800	2760	43	1000	1000	0.01	V	110/73/26.5	50-62
DCR4590B28	2800	2800	4590	65	2000	500	0.007	B	120/84.6/34.87	68-84
DCR4910W28	2800	2800	4910	65	2000	500	0.00631	W	120/84/26.5	68-84
DCR5900A28	2800	2800	5900	79	2000	250	0.00603	A	150/100/35	80-100
DCR5790M28	2800	2800	5790	75	1000	1000	0.005	M	150/100/26.5	80-100
DCR780G30	3000	3000	780	10.5	1000	1000	0.035	G	58/35/26.5	12-18
DCR1460F30	3000	3000	1460	23	1000	1000	0.02	F	75/47/26.5	18-26
Up to 3400V										
DCR470E34	3400	3400	470	6.3	1000	1000	0.041	E	42/25/14.5	4-6
DCR610D34	3400	3400	610	8	1000	1000	0.035	D	47/29/14.5	8-12
DCR650G34	3400	3400	650	8.4	1000	1000	0.035	G	58/35/26.5	12-18
DCR1120F34	3400	3400	1120	17	1000	1000	0.02	F	75/47/26.5	18-26
DCR1430X34	3400	3400	1430	19.2	1000	1000	0.018	X	85/53/26.5	26-34
DCR1970C34	3400	3400	1970	30	1000	1000	0.0125	C	100/63/26.5	40-50
DCR2440V34	3400	3400	2440	33	1000	1000	0.01	V	110/73/26.5	50-62
DCR3640W34	3400	3400	3640	54	1000	1000	0.007	W	120/84/26.5	68-84
DCR4720A34	3400	3400	4720	69	1000	1000	0.057	A	150/100/35	80-100
DCR5110M34	3400	3400	5110	69	1000	1000	0.005	M	150/100/26.5	80-100

Part Number	V _{DRM} (V)	V _{RRM} (V)	I _T (A) at T _C = 60°C (A)	I _{TSM} at T _{vj} V _R = 0 (kA)	dV/dt (V/μs)	Non Rep. di/dt (A/μs)	R _{th(j-c)} (°C/W)	Outline Type Code	Flange OD Contact OD Height (mm)	Clamping Force (kN) min - max
Up to 4200V										
DCR780G42	4200	4200	780	10.5	1500	400	0.0268	G	58.5/34/26.72	10-13
DCR1150N42	4200	4200	1150	16.8	1500	1000	0.0221	N	73/47/34.89	20-25
DCR1260F42	4200	4200	1255	16.8	1500	1000	0.0184	F	73/47/26.72	20-25
DCR2040L42	4200	4200	2040	29	1500	400	0.0117	L	98.9/62.85/34.82	33-41
DCR2150C42	4200	4200	2150	29	1500	400	0.0101	C	98.9/62.9/26.76	33-41
DCR2930Y42	4200	4200	2930	40.6	1500	400	0.00835	Y	112.5/73/35.35	48-59
DCR3030V42	4200	4200	3030	40.6	1500	400	0.00746	V	110/73/27.57	48-59
DCR3790B42	4200	4200	3790	53.5	1500	400	0.007	B	120/84.6/34.87	68-84
DCR4100W42	4200	4200	3880	53.5	1500	400	0.00631	W	120/84.6/27.57	68-84
DCR4500A42	4200	4200	4500	60.8	2000	500	0.00603	A	148/100/35.47	74-91
DCR4880M42	4200	4200	4880	60.8	2000	500	0.00518	M	148/100/26.12	74-91
DCR6140H42	4200	4200	6138	90.91	2000	500	0.004255	H	172/115/35.15	120-155
DCR6650H42	4200	4200	6650	98.56	2000	500	0.004255	H	172/115/35.15	120-155
Up to 5200V										
DCR690G52	5200	5200	690	9.45	1500	300	0.0268	G	58.5/34/26.84	10-13
DCR1020N52	5200	5200	1018	14.8	1500	800	0.0221	N	73/47/34.89	20-25
DCR1110F52	5200	5200	1107	14.8	1500	800	0.0184	F	73/47/26.84	20-25
DCR1850L52	5200	5200	1845	26.25	1500	300	0.0117	L	98.9/62.85/34.94	33-41
DCR1950C52	5200	5200	1950	26.25	1500	300	0.0101	C	98.9/62.9/26.84	33-41
DCR2630Y52	5200	5200	2630	36.7	1500	300	0.00835	Y	112.5/73/35.47	48-59
DCR2720V52	5200	5200	2720	36.7	1500	300	0.00746	V	110/73/27.69	48-59
DCR3480B52	5200	5200	3480	49	1500	400	0.007	B	120/84.6/34.99	68-84
DCR3640W52	5200	5200	3550	49	1500	400	0.00631	W	120/84.6/27.69	68-84
DCR3990A52	5200	5200	3990	53.4	2000	1000	0.00603	A	148/100/35.61	74-91
DCR4330M52	5200	5200	4325	53.4	2000	1000	0.00518	M	148/100/26.26	74-91
DCR5240H52	5200	5200	5240	77.8	2000	500	0.004255	H	170/115/35.27	120-150
DCR5890H52	5200	5200	5890	86.97	2000	500	0.004255	H	170/115/35.27	120-150
Up to 6500V										
DCR490J65	6500	6500	490	6.6	1500	200	0.0379	J	57/33.95/35.15	10-13
DCR590G65	6500	6500	595	6.6	1500	200	0.0268	G	58.5/34/27.1	10-13
DCR820N65	6500	6500	820	12	1500	200	0.0221	N	73/47/35.15	20-25
DCR890F65	6500	6500	894	12	1500	200	0.0184	F	73/47/27.1	20-25
DCR1570L65	6500	6500	1568	22	1500	300	0.0117	L	98.9/62.85/35.2	33-41
DCR1650C65	6500	6500	1650	22	1500	300	0.0101	C	98.9/62.9/27.1	33-41
DCR2220Y65	6500	6500	2220	30	1500	300	0.00835	Y	112.5/73/35.73	48-59
DCR2290V65	6500	6500	2290	30	1500	500	0.0074	V	110/73/27.95	48-59
DCR2880B65	6500	6500	2845	38.5	1500	300	0.007	B	120/84.6/35.25	68-84
DCR2950W65	6500	6500	2945	38.5	1500	300	0.00631	W	120/84.6/27.95	68-84
DCR3220A65	6500	6500	3220	44.2	2000	500	0.00603	A	148/100/35.85	74-91
DCR4420H65	6500	6500	4420	65.6	2000	500	0.00423	H	170/115/35	120-150
DCR4660H65	6500	6500	4660	69.3	2000	500	0.00423	H	170/115/35	120-150
Up to 8500V										
DCR390J85	8500	8500	387	5.25	1500	200	0.0379	J	57/33.95/35.51	10-13
DCR470G85	8500	8500	467	5.25	1500	200	0.0268	G	58.5/34/27.46	10-13
DCR680N85	8500	8500	677	9.8	1500	200	0.0221	N	73/47/35.51	20-25
DCR750F85	8500	8500	733	9.8	1500	200	0.0184	F	73/47/27.46	20-25
DCR1300L85	8500	8500	1300	17.6	1500	400	0.0117	L	98.9/62.85/35.56	33-41
DCR1840Y85	8500	8500	1840	25	1500	300	0.00835	Y	112.5/73/36.09	48-59
DCR1910V85	8500	8500	1910	25	1500	300	0.00746	V	110/73/28.31	48-59
DCR2400B85	8500	8500	2370	32.5	1500	300	0.007	B	120/84.6/35.61	68-84
DCR2450W85	8500	8500	2450	32.5	1500	300	0.00631	W	120/84.6/27.95	68-84
DCR2560A85	8500	8500	2560	32.5	1500	200	0.00603	A	148/100/36.19	74-91
DCR2760M85	8500	8500	2765	32.5	1500	200	0.00518	M	148/100/26.0	74-91
DCR3640H85	8500	8500	3640	54	2000	500	0.00425	H	170/115/35	120-150
DCR3980H85	8500	8500	3980	59.6	2000	500	0.00425	H	170/115/35	120-150

Part Number	V _{DRM} (V)	V _R (V)	I _T (AV) at T _C =80°C (A)	I _{TCM} (A)	dV/dt (V/μs)	di/dt (A/μs)	R _{th(j-c)} (°C/W)	Outline Type Code	Flange OD Contact OD Height (mm)	Snubber Diode	Anti-parallel and Freewheel Diode	Clamping Force (kN) min - max
Asymmetric Types												
Up to 1300V												
DGT304SE	1300	16	250	700	500	500	0.075	E	41.9/25/15	-	DF451	5-6
Up to 1800V												
DGT305SE	1800	16	240	700	500	500	0.075	E	41.9/25/15	-	DF451	5-6
Up to 2500V												
DG306AE	2500	16	225	600	1000	300	0.075	E	41.9/25/15	-	DFS454	5-6
DG406BP	2500	16	500	1200	1000	300	0.041	P	56/38/27	DSF8025SE	DSF8025SE	11-15
DG646BH	2500	16	867	2500	1000	300	0.018	H	100/63/26.5	DSF8025SE	DF051	18-22
Up to 4500V												
DG408BP	4500	16	320	1000	1000	300	0.041	P	56/38/27	DSF8045SK	DSF8045SK	11-15
DG648BH	4500	16	745	2000	1000	300	0.018	H	100/63/26.5	DSF8045SK	DSF20545SF	18-22
DG758BX	4500	16	870	3000	1000	300	0.0146	X	112/66/27	DSF8045SK	DSF21545SV	33-37
DG808BC	4500	16	780	3000	1000	400	0.014	C	108/77.2/27	DSF8045SK	DSF21545SV	28-44
DG858BW	4500	16	1180	4000	1000	300	0.011	W	120/84.6/27.7	DSF8045SK	DSF21545SV	36-44
DG858DW	4500	16	1100	3000	750	300	0.011	W	120/84.6/27.7	DSF8045SK	DSF21545SV	36-44
Reverse Blocking												
Up to 1300V												
DGT304RE	1300	1300	250	700	500	500	0.075	E	41.9/25/15	-	DF451	5-6
Up to 1800V												
DGT305RE	1800	1800	240	700	500	500	0.075	E	41.9/25/15	-	DF451	5-6

Asymmetric Bypass Thyristor

Part Number	V _{DRM} (V)	V _R (V)	I _T (AV) at T _C =80°C (A)	I _{TCM} (A)	dV/dt (V/μs)	Non Rep. di/dt (A/μs)	R _{th(j-c)} (°C/W)	Outline Type Code	Flange OD Contact OD Height (mm)	DC Cosmic Ray Failure Rate @ 50% V _{RRM} (FITs)	Clamping Force (kN) min - max
ACR3200VR33	1000	3300	3200	43	10	1500	0.00746	V	110/73/27.57	9	48-59
ACR2900VR45	1000	4500	2900	39	10	1300	0.00746	V	110/73/27.69	8	48-59

The bypass thyristor range of devices is specially designed for protection of IGBT modules in VSC multi-level applications, where a reduced forward blocking voltage is required. In these applications a thyristor must rapidly divert fault currents from an IGBT diode to protect it from damage. Dynex have designed devices with improved current and surge ratings to assist fault diversion. Such protective thyristors are required to block in parallel with the IGBT diode and as such experience waveforms that are non typical of thyristor applications. They are resistant to fast voltage transients, which they can be exposed to due to the switching of the IGBT diode. The device structures also have greatly enhanced hardness to cosmic ray induced failures which become significant at high duty cycles.

Part Number	V _{DRM} (V)	V _R (V)	I _T (AV) at T _C =80°C (A)	I _{TSM} at T _{vj} V _R =0 (kA)	dV/dt (V/μs)	di/dt (A/μs)	to lpk (kA)	R _{th(j-c)} (°C/W)	Outline Type Code	Flange OD Contact OD Height (mm)	Clamping Force (kN) min - max
Pulsed Power Thyristors (SCR)											
ACR300SG33	3300	20	493	6.5	3000	2000	0.125	0.042	G	58.5/34/27	6-8
PT40QPx45	4500	16	760	13	200	5000	20	0.033	P	56/38/37	11-15
PT60QHx45	4500	16	1000	22.5	175	10000	40	0.013	H	100/63/26.5	18-22
PT85QWx45	4500	16	1670	37	200	22000	90	0.01	W	120/84.6/27.7	36-44

Note: 1. Please contact customer services for the availability of clamps for these devices.

The PT family of Pulsed Power Thyristors (PPTs) is based on Dynex's GTO technology and is designed for long term stability under DC voltages. The structures are resistant to cosmic ray induced failures at normal working voltages. Dynex's Pulsed Power Thyristors may be used to connect a source of stored energy, such as a capacitor, to a load, or to bypass and protect the load in the case of a crowbar circuit. In these pulsed power applications where the rate of rise of current is very fast, the pulsed power switch is acting as a closing switch and ordinary phase control thyristors (SCRs) are likely to fail due to the high di/dt experienced.

Pulsed Power Thyristors may also be required to act in the opening switch mode. Such applications may include those where voltage is reapplied to the pulsed power switch shortly after closing and the switch needs to have recovered blocking capability or the transferred energy needs to be controlled. In these applications, the switch needs to have turn-off capability to reduce the natural turn-off time (t_q) of the device. The device is operated in GTO mode with the appropriate commutating gate drive. Dynex has been supplying thyristors used as crowbars to protect other high power circuitry in railway propulsion units and the like for many years. In addition, Dynex has been a supplier of devices used in equipment for the sterilisation of foods by intense light or x-rays since the late 1980s. These applications operate at moderate di/dts and can be satisfied with conventional thyristor solutions.

In the field of ignitron replacements and weld switches, Dynex has been a world leader in the application of solid state devices. Dynex has been involved in the design and manufacture of assemblies for the pulsed power communities on the West Coast of America and at CERN, Switzerland.

For more information on how Dynex can help with your pulsed power needs, please e-mail us at contactus@dynexsemi.com

Thyristor Components

Take a look at the components that make up our encapsulated device. The devices are fully floating and therefore are not bonded together and are clamped together to achieve electrical and thermal contact instead. This allows our products to have an excellent temperature cycling life expectancy.

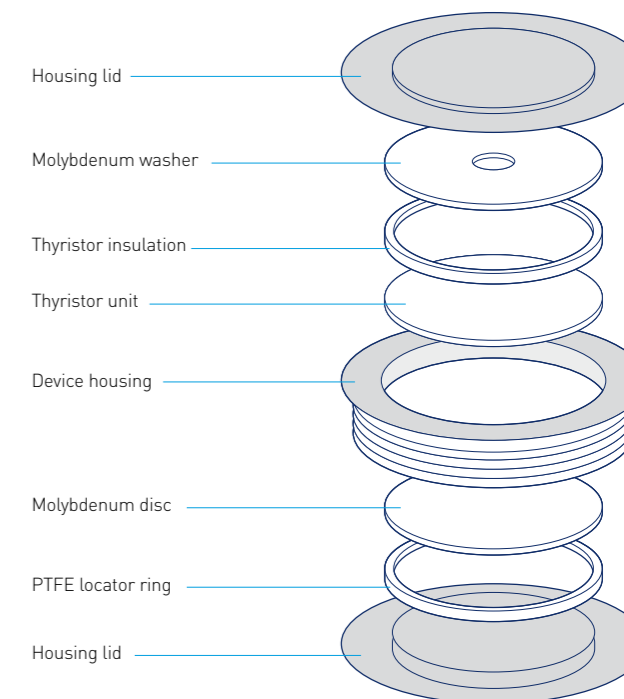

Part Number	V _{RRM} (V)	I _F (AV) at T _C = 100° (A)	I _{FSM} at T _{vj} V _R =0 (kA)	I ² t at T _{vj} V _R = 0 (MA ² s)	R _{th(j-c)} (°C/W)	I _{FM} (A)	V _{FM@ I_{FM} & T_C= 25°C (V)}	Outline Type Code	Flange OD Contact OD Height (mm)	Clamping Force (kN) min - max
Up to 1400V										
DRD520T14	1400	520	5.9	0.17	0.08	800	1.45	T	42/19/13.5	4-6
DRD1360D14	1400	1360	15.2	1.16	0.035	1500	1.3	D	47/29/14.5	8-12
DRD1510G14	1400	1510	16.8	1.41	0.035	1500	1.2	G	58/34/26.5	12-18
DRD2770F14	1400	2770	31	4.81	0.02	1500	1.05	F	75/47/26.5	18-26
DRD3220X14	1400	3220	35.8	6.41	0.018	3000	1.15	X	85/53/26.5	26-34
DRD4650C14	1400	4650	45	10.13	0.0125	3000	1.05	C	100/63/26.5	40-50
DRD6080V14	1400	6080	60	18.00	0.01	3000	1.05	V	110/73/26.5	50-62
Up to 2200V										
DRD410T22	2200	410	4.9	0.12	0.08	800	1.85	T	42/19/13.5	4-6
DRD990D22	2200	990	12.5	0.78	0.035	1500	1.60	D	47/29/14.5	8-12
DRD1100G22	2200	1100	13.9	0.966	0.035	1500	1.45	G	58/34/26.5	12-18
DRD2030F22	2200	2030	25.7	3.30	0.02	1500	1.20	F	75/47/26.5	18-26
DRD2360X22	2200	2360	29.8	4.44	0.018	3000	1.35	X	85/53/26.5	26-34
DRD3430C22	2200	3430	42.2	8.9	0.0125	3000	1.20	C	100/63/26.5	40-50
DRD4460V22	2200	4460	56.4	15.90	0.01	3000	1.15	V	110/73/26.5	50-62
DRD6380W22	2200	6380	78	30.42	0.007	6000	1.09	W	120/84/26.5	62-78
DRD6800A22	2200	6800	94	44.18	0.0057	6000	1.03	A	150/100/35	80-100
DRD8880H22	2200	8880	125	78.13	0.004	6000	0.98	H	172/110/35	110-130
Up to 3400V										
DRD850D34	3400	850	10.8	0.583	0.035	1500	1.95	D	47/29/14.5	8-12
DRD960G34	3400	960	12	0.72	0.035	1500	1.7	G	58/34/26.5	12-18
DRD1830F34	3400	1830	23	2.65	0.02	1500	1.35	F	75/47/26.5	18-26
DRD2050X34	3400	2050	25.8	3.33	0.018	3000	1.55	X	85/53/26.5	26-34
DRD2980C34	3400	2980	36.5	6.66	0.0125	3000	1.35	C	100/63/26.5	40-50
DRD3920V34	3400	3920	49.5	12.25	0.01	3000	1.25	V	110/73/26.5	50-62
DRD5240W34	3400	5240	64.2	20.61	0.007	6000	1.29	W	120/84/26.5	62-78
DRD6140A34	3400	6140	84.4	35.62	0.0057	6000	1.1	A	150/100/35	80-100
DRD7810H34	3400	7810	118	69.62	0.004	6000	1.1	H	172/110/35	110-130
Up to 4000V										
DRD870G40	4000	870	15	1.13	0.032	1800	1.6	G	58.5/34/27	11.5-13.5
DRD1230F40	4000	1225	25	3.13	0.022	3400	1.6	F	73/47/27	18-22
DRD2960Y40	4000	2960	62.5	19.53	0.0095	3000	1.25	Y	112.5/73/37.3	38-47
DRD3390V40	4000	3388	62.5	19.53	0.0075	3000	1.25	V	110/73/26.5	38-47
DRD4350A40	4000	4350	83	34.50	0.007	3000	1.06	A	151/100/37.5	75-91
Up to 4400V										
DRA170E44	4400	170	1.5	0.01	0.115	300	2.1	E	42/25/15	2.5-3.8
Up to 4500V										
DRD2000L45	4500	2000	31	3.92	0.013	3000	1.4	L	102/63/32.9	40-48
DRD6290H45	4500	6290	99.4	49.4	0.004	6000	1.19	H	172/110/36	110-130
Up to 4800V										
DRD1100F48	4800	1105	20.5	2.13	0.022	3400	1.8	F	73/47/27	18-22
Up to 5000V										
DRD710G50	5000	710	11.5	0.66	0.032	1800	1.8	G	58.5/34/ 27	11.5-13.5
DRD2690Y50	5000	2691	55	15.12	0.0095	3000	1.21	Y	112.5/73/37.3	50-62
DRD3080V50	5000	3083	55	15.12	0.0075	3000	1.21	V	110/73/26.5	50-62

Part Number	V _{RRM} (V)	I _F (AV) at T _C = 100° (A)	I _{FSM} at T _{vj} V _R =0 (kA)	I ² t at T _{vj} V _R = 0 (MA ² s)	R _{th(j-c)} (°C/W)	I _{FM} (A)	V _{FM@ I_{FM} & T_C= 25°C (V)}	Outline Type Code	Flange OD Contact OD Height (mm)	Clamping Force (kN) min - max
Up to 5200V										
DRD3770A52	5200	3768	70	24.50	0.0065	3000	1.17	A	148/100/35.0	75-91
Up to 5500V										
DRD5940H55	5500	5940	93.60	43.8	0.004	6000	1.26	H	172/110/36	100-130
Up to 6000V										
DRD630G60	6000	630	10.5	0.555	0.032	1800	2.1	G	58.5/34/27	11.5-13.5
DRD1010F60	6000	1015	16.5	1.425	0.022	3400	2.1	F	73/47/27	18-22
Up to 6500V										
DRD5150H65	6500	5150	82.5	34	0.004	6000	1.65	H	172/110/36	100-130
Up to 7200V										
DRD4950H72	7200	4950	79	31.2	0.004	6000	1.71	H	172/110/36	100-130
Up to 8500V										
DRD4690H85	8500	4690	74.5	27.75	0.004	6000	1.31	H	172/110/36	100-130
Up to 9000V										
DRD560G90	9000	557	10	0.5	0.032	1200	2.08	G	58/34/26.5	11.5-13.5

Fast Recovery Diodes

Part Number	V _{RRM} (V)	I _T (AV) at T _C = 65°C (A)	I _{FSM} at T _{vj} V _R =0 (kA)	I ² t at T _{vj} V _R = 0 (MA ² s)	I _{FM} (A)	V _F (V)	Q _r (μC)	t _{rr} (μs)	Outline Type Code	Flange OD Contact OD Height (mm)	Clamping Force (kN) min - max
Up to 1400V											
DF451	1600	295	3.5	0.061	600	2.65	25	1.22	T	42/19/15	4.5-5.5
Up to 2500V											
DSF8025SE	2500	650	7.5	0.281	1000	2.3	540	5	E	42/25/15	7-9
DF051	2500	1490	14	0.98	1500	1.85	800	5	F	75/47/29	21-25
Up to 4500V											
DSF8045SK	4500	430	3.5	0.061	1000	4	440	3.07	K	42/25/29	7-9
DSF20545SF	4500	1250	16	1.28	1800	2.1	1250	7	F	75/47/29	17.5-21.5
DSF21545SV	4500	3200	20	2	3000	2	1800	7	V	112.5/73/27	34-48
Up to 6000V											
DSF11060SG	6000	400	4.2	0.09	600	3.8	700	6	G	58/35/29	10.8-13.2

Package Outlines

Package Outlines - IGBT Modules

Module Outlines and Circuit Configurations

All dimensions shown in mm unless stated otherwise.

Package Type: D

Nominal weight: 1000g/1600g

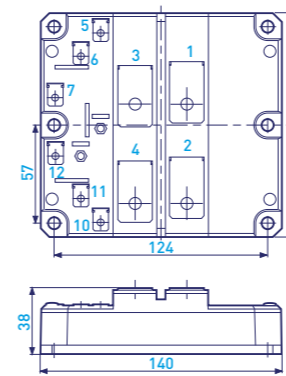

Dual Switch - DDM/S

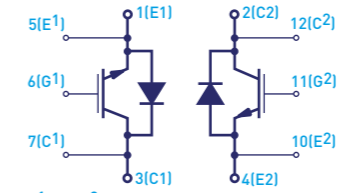

C¹ and C² - Aux Collector
E¹ and E² - Aux Emitter
G¹ and G² - Gate

Chopper switch - DCM/S

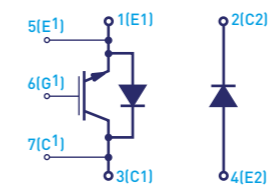

Package Type: E

Nominal weight: 1700g

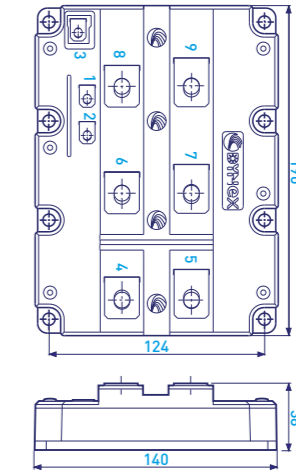

Single Switch - ESM

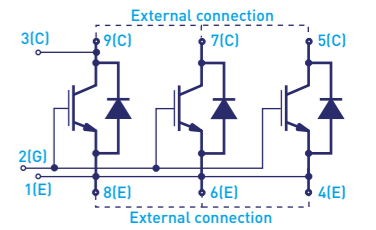

3 - Aux Collector
2 - Gate
1 - Aux Emitter

Package Type: F

Nominal weight: 1000g/1600g

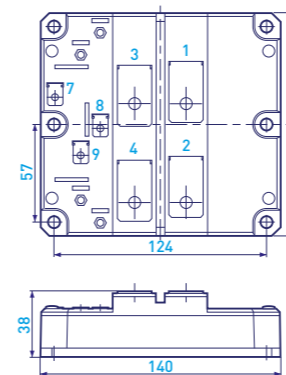

Single Switch - FSM/S

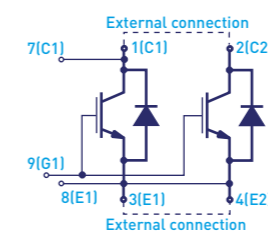

C¹ - Aux Collector
E¹ - Aux Emitter
G¹ - Gate

Package Type: N

Nominal weight: 1000g

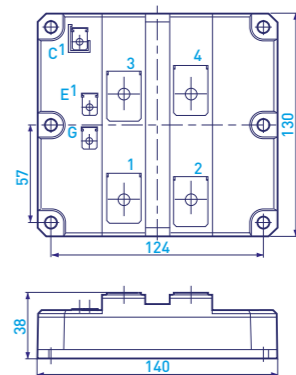

Single Switch - NSM

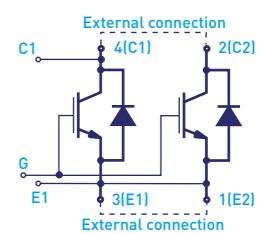

C¹ - Aux Collector
E¹ - Aux Emitter
G - Gate

Package Type: P

Nominal weight: 500/750g

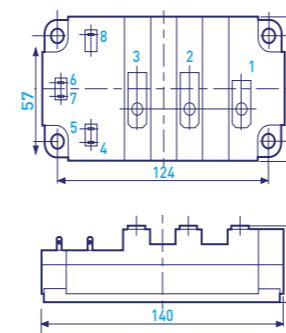

Bi-directional Switch - PBM

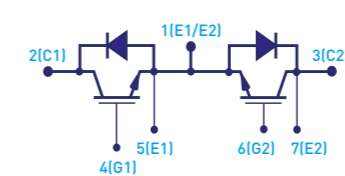

C¹ - Aux Collector
E¹ and E² - Aux Emitter
G¹ and G² - Gate

Half Bridge - PHM

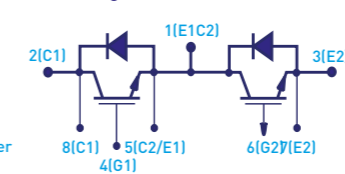

C¹ - Aux Collector
E¹ and E² - Aux Emitter
G¹ and G² - Gate

Package Type: P

Nominal weight: 500g

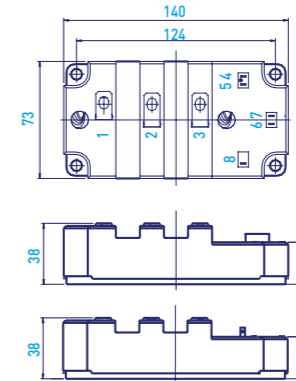

Chopper High Side - PKM

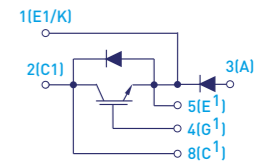

Chopper Low Side - PLM

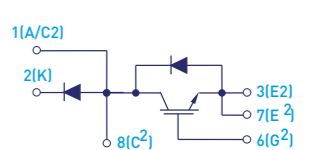

Notes:

1. Mounting recommendations are given in the application note AN4505 'Heatsink Issues For IGBT Modules' available from our website.

Package Outlines - IGBT Modules

Module Outlines and Circuit Configurations

All dimensions shown in mm unless stated otherwise.

Package Type: G

Nominal weight: 1000g

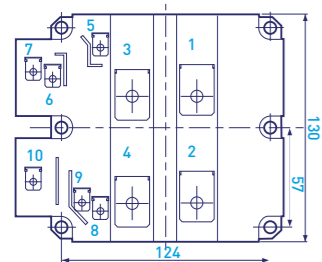

Dual Switch - GDM

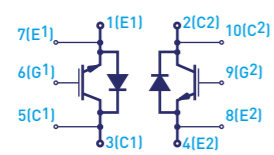

C1 and C2 - Aux Collector
E1 and E2 - Aux Emitter
G1 and G2 - Gate

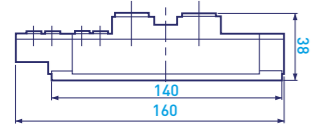

Chopper Switch - GCM

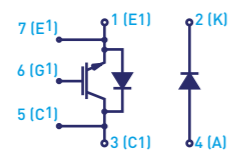

C1 and C2 - Aux Collector
E1 and E2 - Aux Emitter
G1 and G2 - Gate

Package Type: X

Nominal weight: 1100g

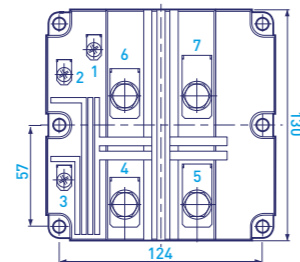

Single Switch - XSM

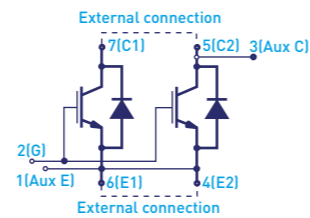

Chopper Switch - XCM

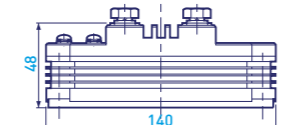
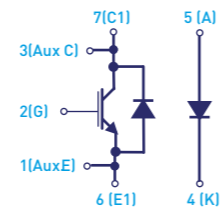

Package Outlines - FRD Modules

Module Outlines and Circuit Configurations

All dimensions shown in mm unless stated otherwise.

Package Type: E

Nominal weight: 1700g

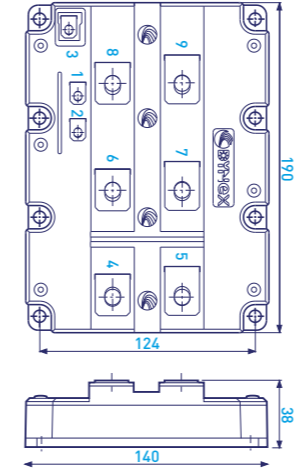

Triple Diode - EXM

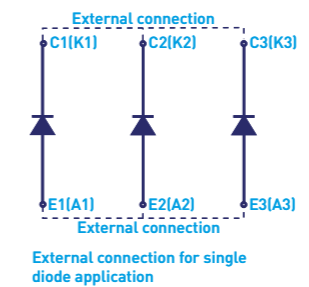

External connection for single diode application

Package Type: X

Nominal weight: 1100g

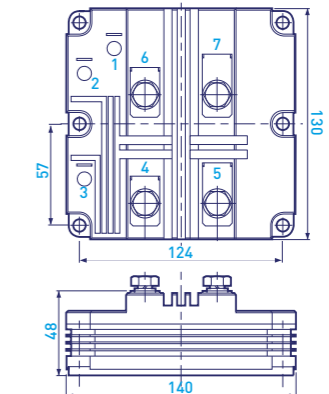

Dual Diode - XXM

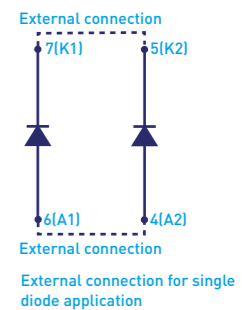

External connection for single diode application

Package Type: A

Nominal weight: 1700g

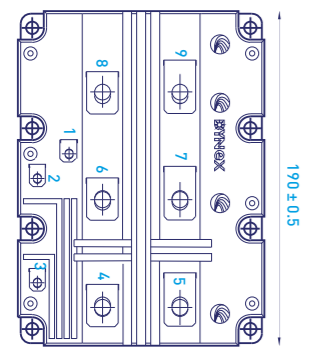

Single Switch - ASM

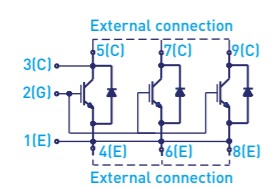

Chopper Switch - ACM

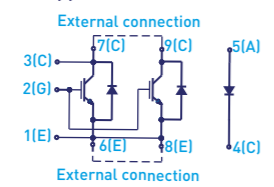

3 - Aux Collector
2 - Gate
1 - Aux Emitter

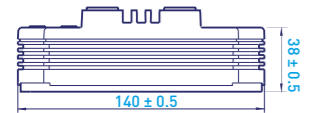

Package Type: F

Nominal weight: 1000g/1600g

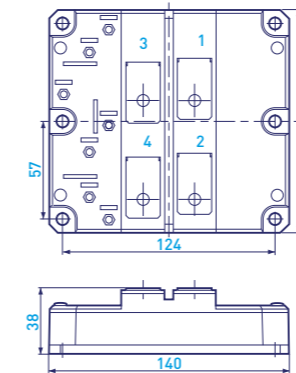

Dual Diode - FXM/S

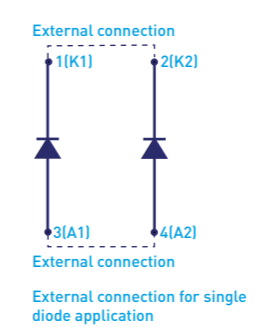

External connection for single diode application

Package Type: N

Nominal weight: 1000g

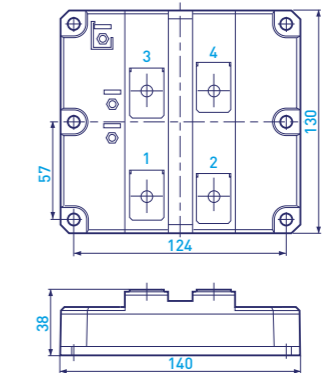

Dual Diode - NXM

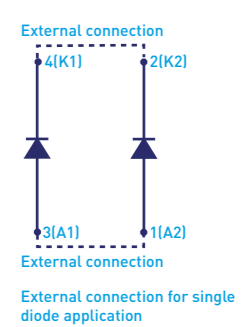

External connection for single diode application

Package Type: P

Nominal weight: 500g

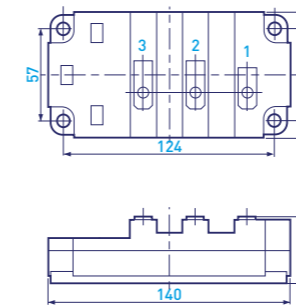

Series Diode - PXM



Notes:

1. Mounting recommendations are given in the application note AN4505 'Heatsink Issues For IGBT Modules' available from our website.

Notes:

1. Mounting recommendations are given in the application note AN4505 'Heatsink Issues For IGBT Modules' available from our website.

Package Outlines

Thyristor and Diode Outlines

For detailed dimensions, see datasheet on www.dynexsemi.com

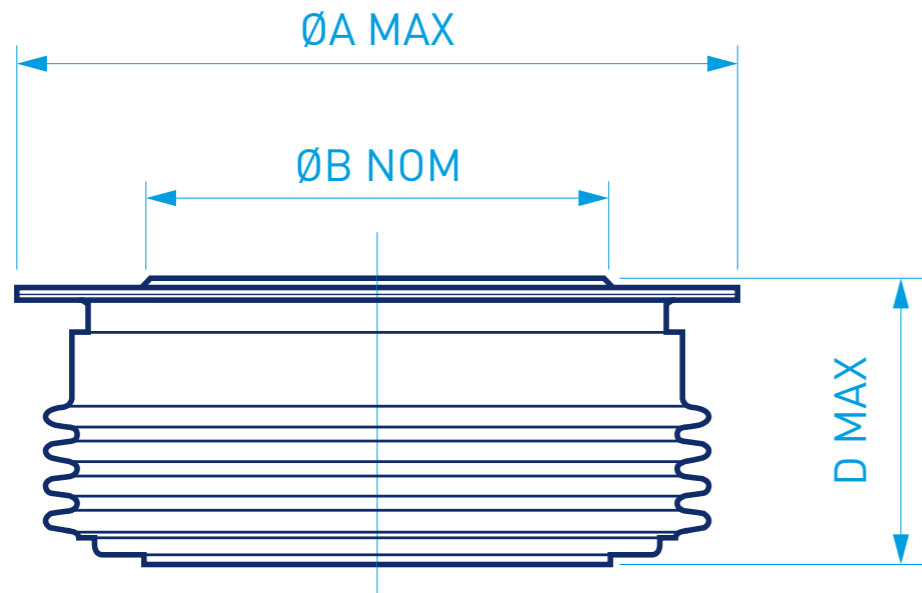

Outline	Flange (A) [mm] Max*	Pole (B) [mm] Nominal*	Depth (D) [mm] Maximum	Weight (kg)
A	148 & 150	100	37	2.6
B	120	85	36	1.5
C	99 & 102	63	28	0.8
D	47	29	15	0.24
E	42	25	15	0.082
F	73 & 75	47	28	0.433
G	57 & 58	35	28	0.25
H	172	110	36	3.5
J	57 & 58	34	36	0.322
K	42	25	27	0.16
L	99 & 100 & 102	63	36	1.05
M	148 & 150	100	27	1.95
N	73 & 75	47	36	0.48
T	42	19	15	0.055
V	110 & 112	73	29	1.1
W	120	84	29	1.55
X	85	53	27	0.6
Y	112 & 120	73 & 78	36	1.45

Notes:

*The character '&' denotes we manufacture products in a generic outline, some of which have one flange/contact diameter and others that have a slightly different flange/contact diameter. There is no choice of flange/contact diameter for a specific device.

Package Outlines

GTO Outlines

For detailed dimensions, see datasheet on www.dynexsemi.com

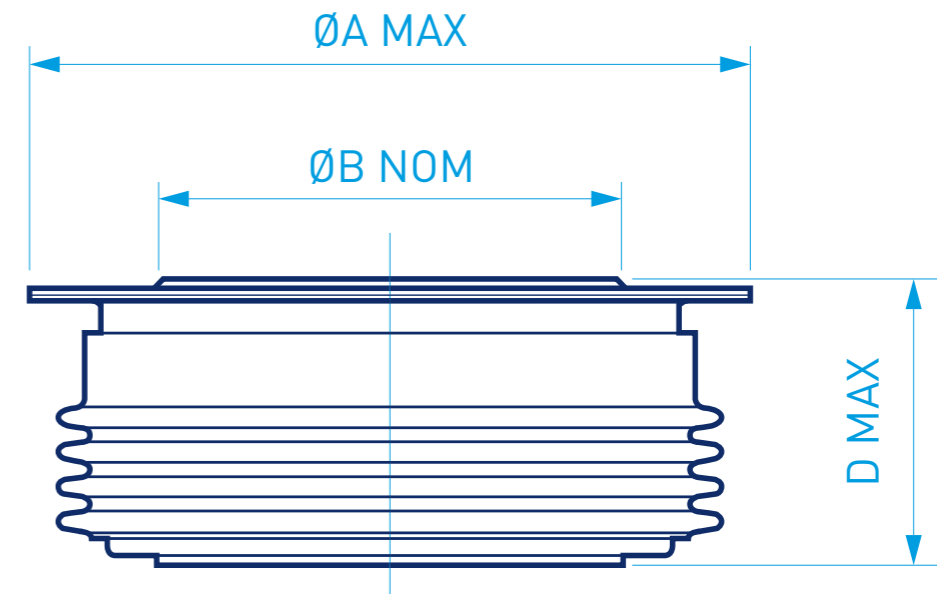

Outline	Flange/Max OD (A) [mm]	Pole (B) [mm]	Depth (D) [mm]	Weight (kg)
C	108	77	27	1.4
E	42	25	15	0.082
CA	56	38	36	0.46
H	100	63	27	0.82
P	56	38	27	0.35
W	120	85	27	1.7
v	85	53	27	1.2

Power Assemblies



Power Assemblies

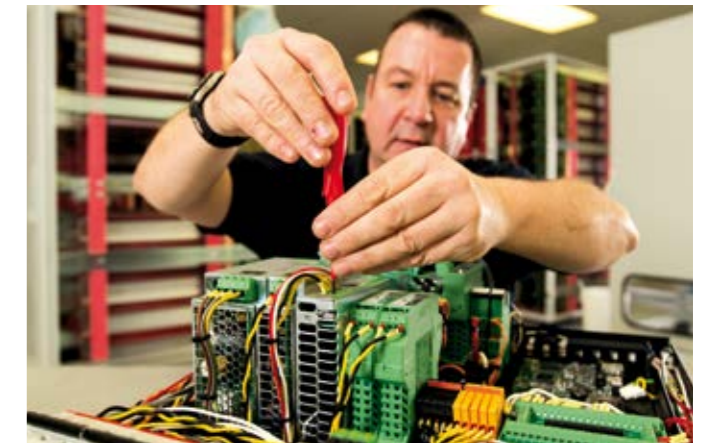
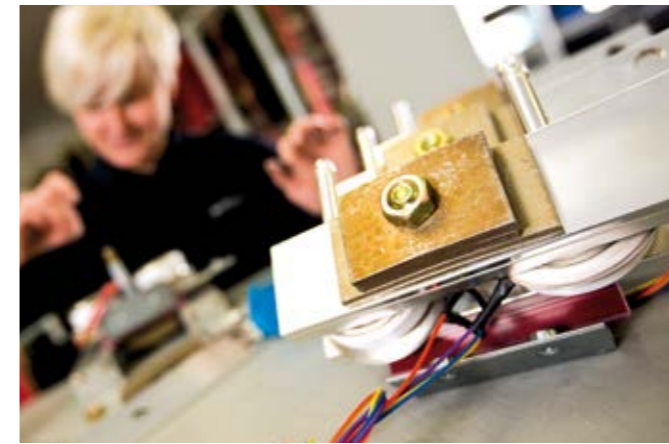
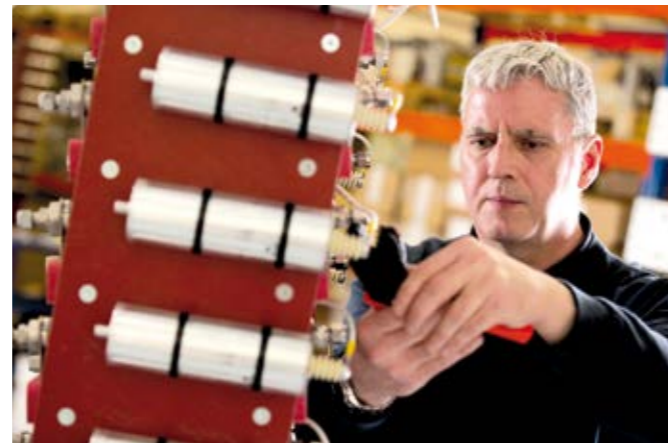

Power Assembly Products

In addition to the discrete product lines, Dynex offers a design, build and refurbishment service for power assemblies through our Power Electronic Assemblies group. This group provides support for customers requiring more than the basic semiconductor and utilises the skills of our power electronics, mechanical and electronic engineers. The team has direct access to the company's application, test and product design personnel to produce the optimum solution for your requirements.

Power Assembly Products

Typical applications for Dynex power assemblies include:

- High power rectification
- Inverters
- Battery chargers
- Resistance welding switches
- GTO gate drive units
- Pulse power switches
- Soft starts
- Magnet supplies
- Variable speed drives
- Static compensation stacks

Dynex also has a range of air and liquid cooled heatsink and clamping systems.

Standard Assemblies

Many factors need to be taken into consideration to maximise semiconductor performance in an assembly. Typically these are; type of heatsink, transient conditions, overloads, ambient temperature, surface finish (e.g. black anodised) and the method of cooling on which the application relies (air, liquid or phase change). With a wealth of experience behind them and using 3D CAD and simulation software, our designers have a vast range of bipolar and IGBT power semiconductor devices and components available which will ensure that even standard power assemblies are optimised for customer applications.

Rectifiers

Standard diode and thyristor rectifier combinations include:

- 3-phase and dual 3-phase diode rectifier assemblies
- 3-phase (6 pulse) and dual 3-phase (12 pulse) controlled assemblies

Inverters/Converters

- 3-phase thyristor inverter power units
- IGBT chopper H-bridge inverter modules
- IGBT full 3-phase inverters for motor control
- Frequency converters

Stack Assemblies

- Stick stacks for high voltage, high current applications
- MV soft starts
- Crowbars
- Thyristor/GTO assemblies with anti-parallel diode combinations
- Air cooled and water cooled stack assemblies

Pulsed Power Systems

For many pulsed power applications, semiconductor switches can offer advantages over alternative switch technologies. These advantages include:

- Increased number of operations and reliability
- Improved waveform shaping and pulse control
- Increased rep rate
- Higher current pulses

The choice of semiconductor device is critical for correct and reliable operation and Dynex have a wide range of thyristor types, including some which have been specifically developed for high di/dt pulsed power applications. In addition, Dynex have many years of experience in providing specific assemblies for custom Pulsed Power requirements. Typically used for:

1. Connection of energy storage to low inductance loads
2. Crowbars for by-passing / protecting a load
3. General thyatron and ignitron replacements

Contract Assembly Refurbishment and Customised Projects

The manufacturing facility has a proven capability for building and testing high power semiconductor assemblies. This capability is offered to third party customers looking for a ready built power assembly operation to provide part or complete solutions for this type of manufacturing. This service extends to refurbishment of these assemblies, where the units can be renovated with the latest technology components giving them extended operating life and renewed long term reliability

SVC Valve Stacks

Thyristor Controlled Reactors (TCRs) are used, usually in combination with Fixed or Mechanically Switched Capacitors (FC or MSC) to provide Static VAR Compensation. This helps improve the quality of the mains voltage supply by compensating for large loads with poor power factors. Typical example applications include flicker reductions and power factor compensation of Electric Arc Furnaces in steel mills. Dynex provide a range of water cooled TCR valves from 12MVAR up to 100MVAR. These can be used in both single phase and three phase applications. The Dynex range of TCRs has been designed with optimum performance and availability in mind. All the thyristor modules used in the TCR valves are matched to improve static and dynamic sharing whilst N+1 redundancy is included as standard to ensure consistent availability of supply, even in the harshest of operating conditions.

Heatsinks Clamps and Accessories

Device Clamps

A line of pre-loaded clamps is offered, up to 180kN for our 150mm disc devices. Bar clamps are suitable for single and double side cooling, with high insulation versions available for high voltage assemblies.

Heatsinks

Dynex has its own proprietary range of extruded aluminium heatsinks designed to optimise the performance of our semiconductors. Additionally, Dynex has access to a vast range

of aluminium extrusions from independent manufacturers giving our design team the best options available. Water cooled heatsinks (coolers) are available and are compatible with devices up to 100mm silicon diameter. These are designed for use in high current, high power assemblies such as single, three or six phase bridges or AC controllers. Complete bridges of up to six devices may be constructed and two coolers per device may be used for double side cooling.

Accessories

Dynex can also provide a wide range of accessories, such as gate firing boards, voltage dividers, optical combiner and splitter boards, GLPS (Ground Level Power Supply) and high voltage isolated stack firing systems for multi level stacks (typically 10 levels)

High Power Test Equipment

The Dynex Equipment Group have designed a wide range of testers which can capture all of the electrical and timing measurements required to define the performance of high power semiconductor devices (Thyristors, Diodes, GTO's and IGBT's). Having provided this type of equipment for internal use for 30 years, Dynex have developed a capability to provide low cost customised test solutions for third party companies.

This capability has been developed to enable test systems to be offered for a wide variety of applications which are not always for semiconductor testing. E.g. Fuse testing, lightning simulation, breaker testing, capacitor reliability, resistor thermal cycling, crowbar testing etc.

Our engineering team are able to review custom requirements for high voltage and high current testing and to design the hardware solution to meet these requirements. Amongst our existing designs we have produced the following systems in the field:-

Passive thermal cycling equipment, power cycling equipment, dynamic IGBT testers, high voltage hot blocking equipment, low voltage hot test equipment, Qrr and Tq testing, multiple cycle surge testing, thyristor high power parametric test systems and high voltage leakage measurement systems.

Symbols and Definitions

C_s	Snubber capacitance	P_G	Gate power dissipation
di/dt	Critical rate of rise of on-state/forward current	P_{G(AV)}	Mean gate power dissipation
di_{F6}/dt	Rate of rise of positive gate current	P_{GM}	Peak gate power dissipation
di₆₀/dt	Rate of rise of reverse gate current (GTO)	Q_r	Recovered charge
di_T/dt	Critical rate of rise of on-state current (GTO)	Q_{rr}	Reverse recovery charge
dsc	Double side cooled	r_T	On-state/forward slope resistance
dV/dt	Critical rate of rise of off-state voltage	R_{th(c-hs)}	Thermal resistance – case to heatsink
dIV_D/dt	Rate of rise of off-state voltage (GTO)	R_{th(j-c)}	Thermal resistance – junction to case
E_{OFF}	Turn-off energy loss	R_{th(j-hs)}	Thermal resistance – junction to heatsink
E_{rec}	Reverse recovery energy	R_{th(j-w)}	Thermal resistance – junction to water
E_{sw(TOT)}	Total switching energy	T_c	Case temperature
F_m/F	Clamping force/mounting torque	t_{gq}	Gate controlled turn-off time
I²t	I ² t value	t_q	Turn-off time
I_c	Collector current	t_{rr}	Reverse recovery time
I_{c(PK)}	Peak collector current	T_{HS}	Heatsink temperature
I_{DRM}	On-state leakage current (thyristor)	T_{vj}	Virtual junction temperature
I_F	Forward current (diode)	T_{vjm}	Maximum virtual junction temperature
I_{F(AV)}	Mean forward current (diode)	T_{water}	Water temperature
I_{FM}	Peak forward current (diode)	V_{CE(sat)}	Collector-emitter saturation voltage (IGBT)
I_{F(RMS)}	RMS forward current (diode)	V_{CES}	Collector-emitter voltage (IGBT)
I_{FSM}	Single cycle surge current (diode), (10ms half sinewave)	V_{DRM}	Repetitive peak off-state voltage
I_{G(ON)}	Gate turn-on current (GTO)	V_{DSM}	Non-repetitive peak off-state voltage
I_{GT}	Gate trigger current	V_F	Forward voltage (diode)
I_{RMS}	RMS line current	V_{FM}	Peak forward voltage (diode)
I_{PK}	Peak current	V_{isol}	Isolation voltage
I_{RRM}	Peak reverse recovery current	V_{GT}	Gate trigger voltage
I_{T(RMS)}	RMS on-state current (thyristor)	V_R	Reverse voltage
I_{T/I_{TM}}	On-state current	V_{RRM}	Repetitive peak reverse voltage
I_{T(AV)}	Mean on-state current (thyristor)	V_{RSM}	Non-repetitive peak reverse voltage
I_{TCM}	Maximum repetitive controllable current (GTO)	V_T	On-state voltage
I_{TSM}	Single cycle surge current (thyristor), (10ms half sinewave)	V_{TM}	Peak on-state voltage
		V_{TO}	Threshold voltage (diode)
		V_{T(TO)}	Threshold voltage (thyristor)

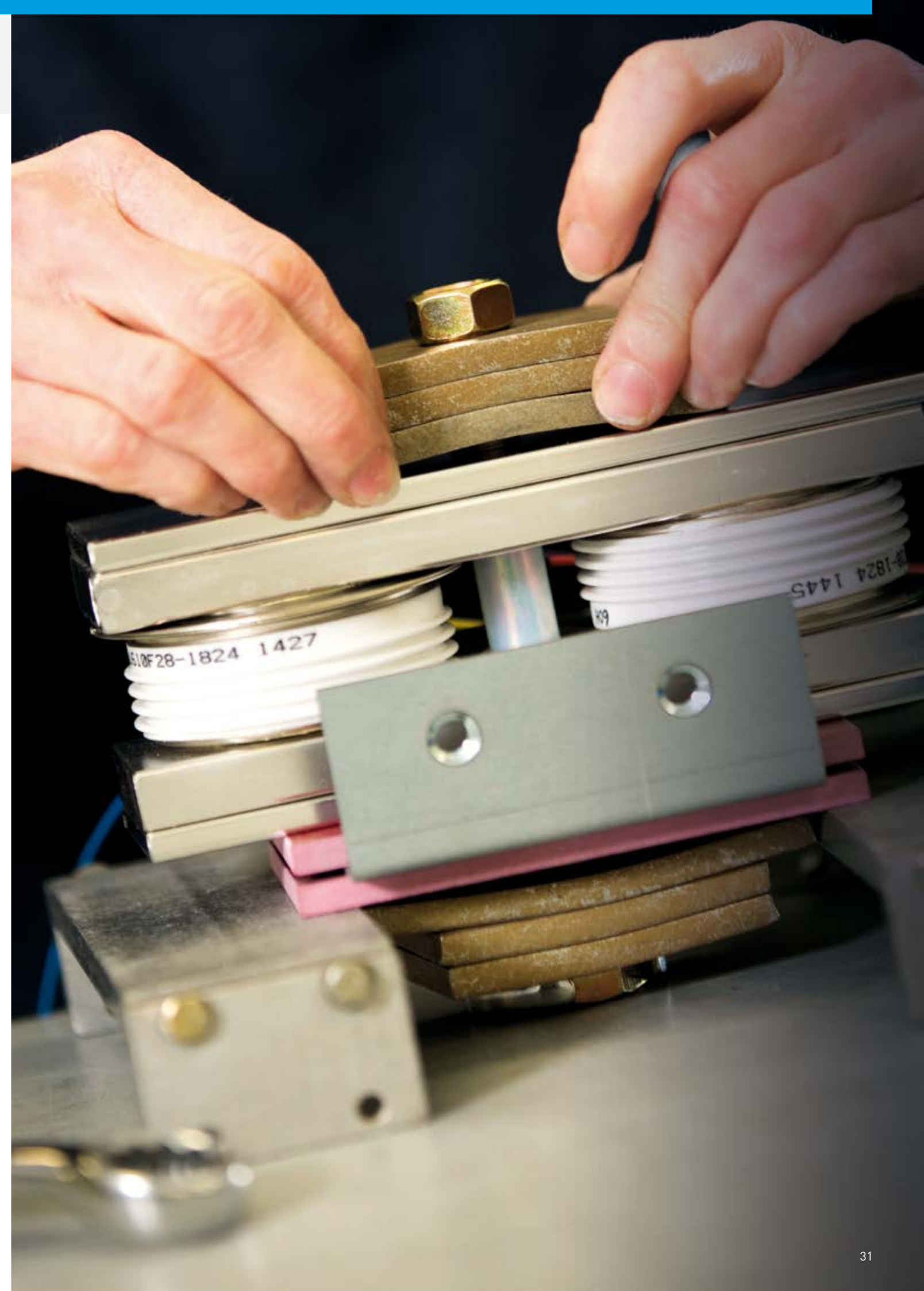

Important Information

This publication is provided for information only and not for resale.

The products and information in this publication are intended for use by appropriately trained technical personnel.

Due to the diversity of product applications, the information contained herein is provided as a general guide only and does not constitute any guarantee of suitability for use in a specific application. The user must evaluate the suitability of the product and the completeness of the product data for the application. The user is responsible for product selection and ensuring all safety and any warning requirements are met. Should additional product information be needed please contact Customer Service.

Although we have endeavoured to carefully compile the information in this publication it may contain inaccuracies or typographical errors. The information is provided without any warranty or guarantee of any kind.

This publication is an uncontrolled document and is subject to change without notice. When referring to it please ensure that it is the most up to date version and has not been superseded.

The products are not intended for use in applications where a failure or malfunction may cause loss of life, injury or damage to property. The user must ensure that appropriate safety precautions are taken to prevent or mitigate the consequences of a product failure or malfunction.

The products must not be touched when operating because there is a danger of electrocution or severe burning. Always use protective safety equipment such as appropriate shields for the product and wear safety glasses. Even when disconnected any electric charge remaining in the product must be discharged and allowed to cool before safe handling using protective gloves.

Extended exposure to conditions outside the product ratings may affect reliability leading to premature product failure. Use outside the product ratings is likely to cause permanent damage to the product. In extreme conditions, as with all semiconductors, this may include potentially hazardous rupture, a large current to flow or high voltage arcing, resulting in fire or explosion. Appropriate application design and safety precautions

Dynex's advice to customers on Counterfeit Goods

It has been brought to our attention that an increasing number of counterfeit products are appearing on the semiconductor marketplace.

Unfortunately, many of these products will have markings and labels that closely resemble those from Dynex's genuine products, making it difficult to realise the difference. Dynex has extensive, proven controls to ensure our products are properly manufactured, tested, handled, and stored to prevent failures. Counterfeit products will not have been subjected to these processes. Therefore, Dynex does not warrant any parts purchased through unauthorized channels nor do we accept any liability for failure of counterfeit products.

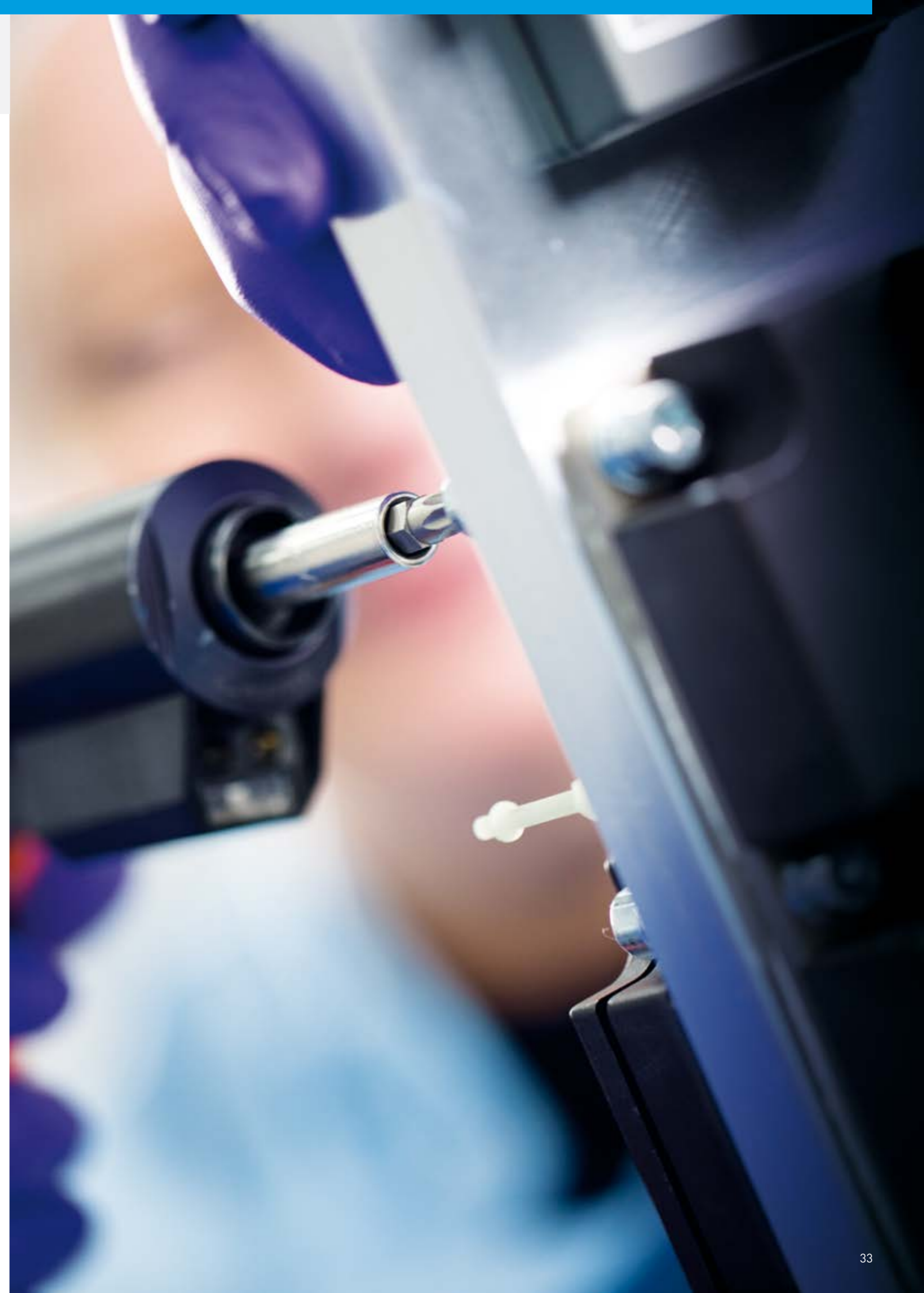



Dynex Semiconductor Ltd
Doddington Road
Lincoln LN6 3LF
United Kingdom

Email: contactus@dynexsemi.com
Main switchboard: **+44 (0)1522 500 500**
Sales & Marketing: **+44 (0)1522 502 901**

www.dynexsemi.com

 [@Dynexpower](https://twitter.com/Dynexpower)

 [/DynexSemiconductor](https://www.facebook.com/DynexSemiconductor)

 [Dynex Semiconductor Ltd](https://www.linkedin.com/company/dynex-semiconductor-ltd)