

Clamping of Power Semiconductors

Application Note

AN4839-4 November 2015 LN33076

The Forward Voltage Drop and Thermal Resistance of a hockey puck semiconductor are affected by the clamping force applied to the device. This is because, unlike stud type devices, the internal interfaces between for instance the copper electrodes and the molybdenum discs and washers, used in the construction, are dry. These interfaces contribute a contact electrical and thermal resistance which add to the bulk resistances of the materials that constitute the device. Figure 1 shows the theoretical thermal resistance versus clamping pressure for the dry interfaces in a Dynex i^2 fully floating thyristor.

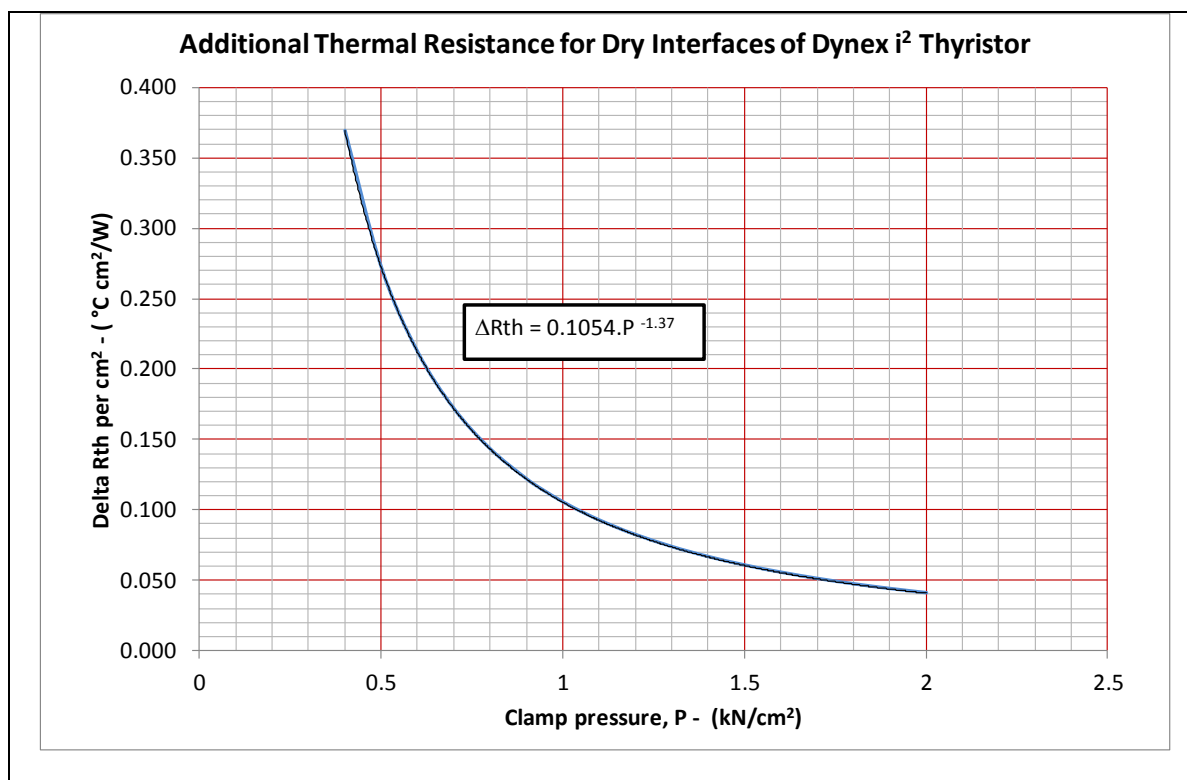

Figure 1 Thermal resistance of dry interfaces of a fully floating thyristor.

The clamping force recommended by Dynex Semiconductor in its data sheets has been established as being that force necessary to give good thermal and electrical contact between the internal and external interfaces of the device and heat-sinks. To determine this, Dynex Semiconductor measures the Forward Voltage Drop and Thermal Resistance of the device at different clamping forces, see figures 2 & 3.

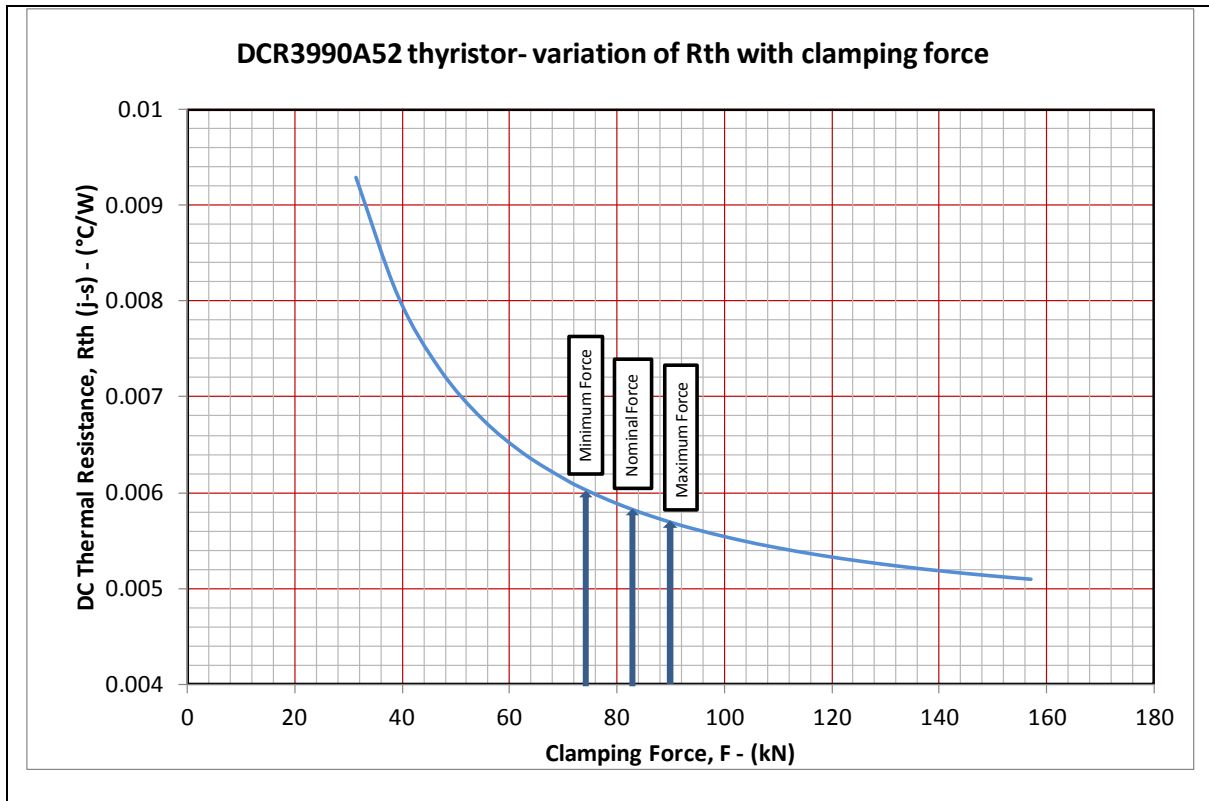

Figure 2 DCR3990A52 thyristor – variation of thermal resistance with clamping force.

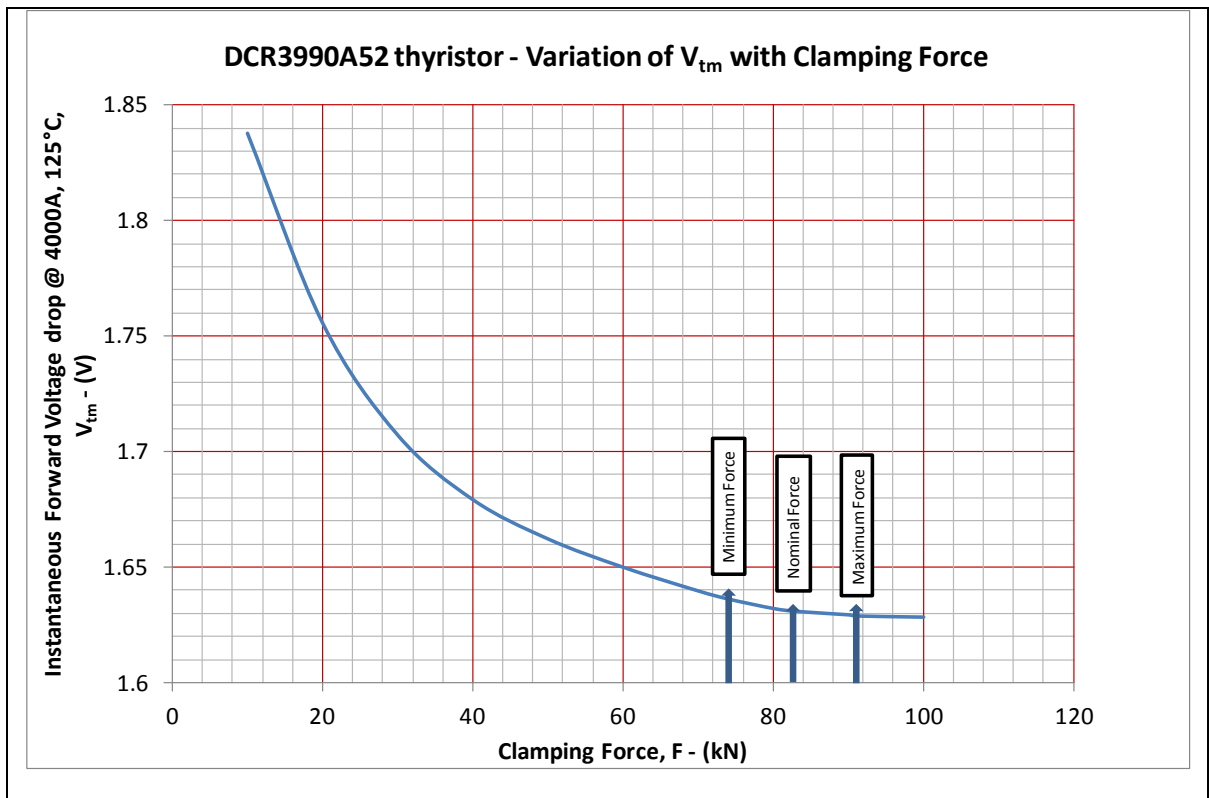

Figure 3 DCR3990A52 thyristor – variation of Forward Voltage Drop with clamping

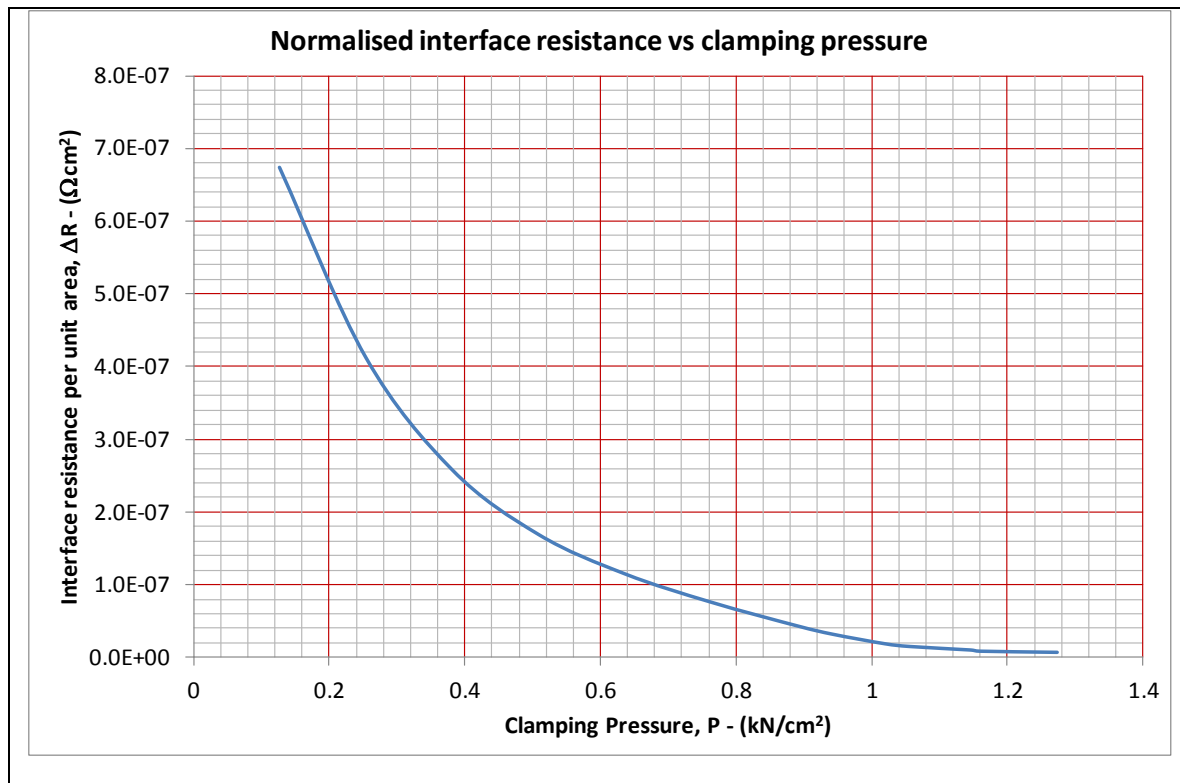

Figure 4 Normalised interface resistance variation with clamping pressure

The minimum clamping force is determined as the force above which the Thermal Resistance and Forward Voltage Drop do not improve significantly. The maximum recommended clamping force is then taken to be 1.22 x the minimum value. The device is then subjected to temperature cycling tests at this higher force to verify that thermal expansion and contraction does not lead to degradation. The published figure is the mean value $\pm 10\%$.

It is important, therefore, that the user takes due regard that clamping forces remain between these limits under all conditions that arise from variations in tolerances of the clamps and any thermal expansion and contraction that may affect their settings. In this way the user will be assured that the thermal and electrical characteristics are within those specified on the datasheet and that long term tolerance to thermal cycling has been verified.

Of course, this clamping force must be evenly distributed over the entire surface of the semiconductor to ensure that the above conditions are obtained. Uneven clamping can result in high thermal resistance, forward voltage drop and mechanical damage to the thyristor. Care must, therefore, be taken to ensure that the clamp applies force to the centre of the pole piece and that it is subsequently spread evenly over the whole contact area by means of suitably thick and stiff buffers.

A note of warning about the clamping of fully floating devices at room temperature and then applying heat from an external source during testing. This heat could come from a hot plate or oven used to raise the device temperature or perhaps indirectly from an adjacent device being tested on a power run.

Silicon is very strong in compression but relatively weak in tension. Because of the temperature coefficients of expansion of the metal components in the thyristor housing are greater than that of silicon, if heat is applied from the outside of the puk, the metal components will put the silicon into tension and cracking can occur. If the heat is internally generated in the silicon as in service, the silicon remains in compression and un-cracked.

NOTES ON MOUNTING HOCKEY PUK SEMICONDUCTORS ONTO HEATSINKS USING DYNEX SEMICONDUCTOR CLAMPS.

NOTE: *Too little jointing compound will lead to high thermal resistance. However, a more common error is to apply too much compound which can give high electrical contact resistance.*

DOUBLE SIDE COOLED.

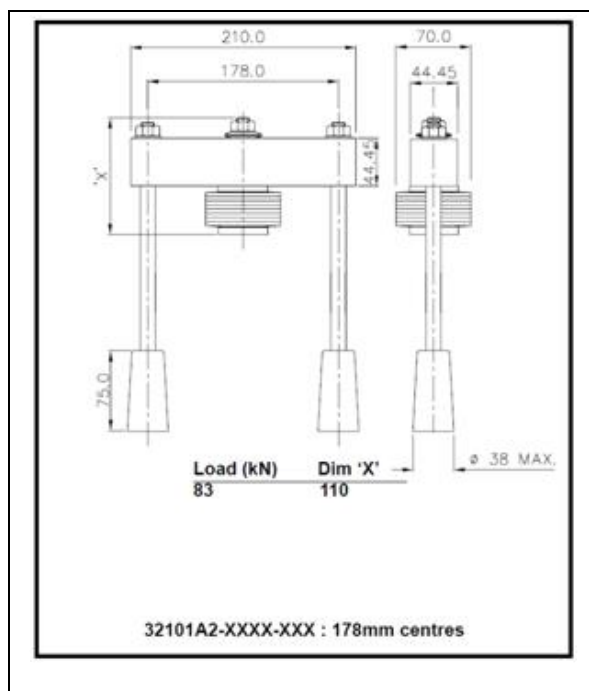

Figure 5 Typical Clamp for Double Side Cooling

1. Check that the clamping force (in kN) printed on the bar is suitable for the device to be clamped (see data-sheet)
2. Slip the polyester film locator over the disc device
3. Prepare the heat-sink surface by abrading the aluminium surface using medium grade emery cloth such as ELC120 or 3M Scotchbrite™ pad, degrease with a solvent and carry out the mounting operation the same day. Similarly prepare the semiconductor device and then apply a small amount of jointing or interface compound, see “Mounting Compounds” below.
4. After loosely assembling all the components with the disc device between the heat-sinks, finger tighten the two nuts on the tie bolts until they just touch their washers. Check that the bar is reasonable parallel with the heat-sink and make sure that it is centrally located, i.e. not at an angle to the channel in the heat-sink.
5. Using a socket spanner (wrench) at the bar end (and , if necessary, a nut runner to hold the threaded rod by means of its “ Loctited” nut in the ceramic insulator) carefully tighten each

nut alternatively, a flat at a time. Apply a steady finger pull on the gauge under the central nut and when it comes free, cease to tighten the nuts. Slide the gauge to the full extent of its slot until the top leaf springs up to prevent the gauge slipping back under the nut. This procedure provided a gap of 0.3mm under the nut and will allow for any relaxation of the clamp, fins or device while in service. The heights at each end of the bar above the heat-sink should be within 1.0mm of each other.

6. If it is necessary to re-adjust the clamp or remove the device then, before loosening the tie rods, slip the two leaves of the gauge back underneath the central nut. This procedure will re-set the bar-clamp for further use.
7. A useful check of good mounting is to measure the electrical contact resistance of the device to heat-sink joint. 100A d.c. may pass across the joint and we recommend the maximum value should not exceed $2\mu\Omega$ (0.2mV drop) for large devices and critical applications and $10\mu\Omega$ (1.0mV) for smaller devices or less critical applications. High contact resistance may lead to the device overheating and/or pitting of the contact surfaces.

Warning: The central pressure bolt assembly is pre-set in the factory and sealed. Any subsequent adjustment of this bolt will alter the clamping force when tightened on the device and damage may result to the device by either lack of or excess clamping force.

SINGLE SIDE COOLED

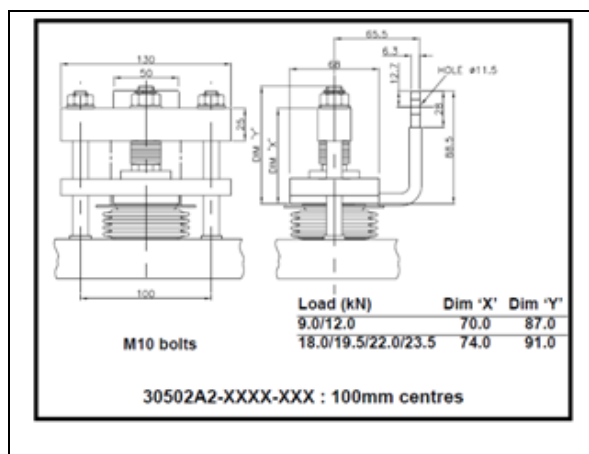

Figure 6 Typical Clamp for Single Side Cooling

1. Check that the clamping force (in kN) printed on the bar is suitable for the device to be clamped (see data-sheet)
2. Slip the polyester film locator over the disc device
3. Prepare the heat-sink surface by abrading the aluminium surface using medium grade emery cloth such as ELC120 or 3M Scotchbrite™ pad, degrease with a solvent and carry out the mounting operation the same day. Similarly prepare the semiconductor device and then apply a small amount of jointing or interface compound, see "Mounting Compounds" below.
4. Place the semiconductor device, the appropriate way up, on the heatsink followed by the busbar/ insulator assembly. A small amount of heatsink compound should be applied between the disc and the busbar to prevent corrosion.
5. Place the pressure bar on top of the busbar/insulator assembly with the hexagon head of the central bolt bearing down on the insulator. The two insulated bolts should then be

inserted through the holes on the pressure assembly, the busbar insulator assembly and the device locator, thereby aligning all three. Adjust the position of the gate connector on the semiconductor device to suit the insulation.

6. Screw the bolts into the heat-sink making sure that the pressure bar is kept parallel to the heat-sink. When the bolts start pulling down the pressure bar, tighten each bolt alternatively a flat at a time. Apply a steady finger pull on the gauge under the central nut and when it comes free, cease to tighten the nuts. Slide the gauge to the full extent of its slot until the top leaf springs up to prevent the gauge slipping back under the nut. This procedure provided a gap of 0.3mm under the nut and will allow for any relaxation of the clamp, fins or device while in service. The heights at each end of the bar above the heat-sink should be within 1.0mm of each other.
7. A useful check of good mounting is to measure the electrical contact resistance of the device to heat-sink joint. 100A d.c. may pass across the joint and we recommend the maximum value should not exceed $2\mu\Omega$ (0.2mV drop) for large devices and critical applications and $10\mu\Omega$ (1.0mV) for smaller devices or less critical applications. High contact resistance may lead to the device overheating and/or pitting of the contact surfaces.
8. If it is necessary to re-adjust the clamp or remove the device then before loosening the tie rods, slip the two leaves of the gauge back underneath the central nut. This procedure will re-set the bar-clamp for further use.

MOUNTING COMPOUNDS

It is important to use a suitable interface compound between a semiconductor and its heat-sink. Two basic types are available:

- As designed for interfaces which are both thermally conducting and current carrying. This type was originally developed for electrical busbar joints is referred to as a filled grease and contains metal or metal oxide particles.
- Developed only for good thermal performance. These are usually oils. Synthetic oils are preferable to mineral oils as they do not affect other materials.

	Rhodorsil 47V5	Dow Corning DC200	Aavid Thermalloy Sil Free	American Oil PQ Compound	Prysmian BICON BX13	Aremco Heataway™	Unial Universal Jointing Compound	Xiameter PMX-200
Max Temp	120°C	315°C	200°C	200°C	260°C	285°C	120°C	315°C
Min Temp	-65°C	-50°C	-40°C	-	-	-	-30°C	-50°C
Thermal Conductivity	0.12W/m.K	0.155W/m.K	0.793W/m.K	0.699W/m.K	-	9.665W/m.K	-	0.155W/m.K
Dielectric Strength	15V/m	-	0.225V/m	15V/m	0	0	0	-

IMPORTANT INFORMATION:

This publication is provided for information only and not for resale.

The products and information in this publication are intended for use by appropriately trained technical personnel.

Due to the diversity of product applications, the information contained herein is provided as a general guide only and does not constitute any guarantee of suitability for use in a specific application. The user must evaluate the suitability of the product and the completeness of the product data for the application. The user is responsible for product selection and ensuring all safety and any warning requirements are met. Should additional product information be needed please contact Customer Service.

Although we have endeavoured to carefully compile the information in this publication it may contain inaccuracies or typographical errors. The information is provided without any warranty or guarantee of any kind.

This publication is an uncontrolled document and is subject to change without notice. When referring to it please ensure that it is the most up to date version and has not been superseded.

The products are not intended for use in applications where a failure or malfunction may cause loss of life, injury or damage to property. The user must ensure that appropriate safety precautions are taken to prevent or mitigate the consequences of a product failure or malfunction.

The products must not be touched when operating because there is a danger of electrocution or severe burning. Always use protective safety equipment such as appropriate shields for the product and wear safety glasses. Even when disconnected any electric charge remaining in the product must be discharged and allowed to cool before safe handling using protective gloves.

Extended exposure to conditions outside the product ratings may affect reliability leading to premature product failure. Use outside the product ratings is likely to cause permanent damage to the product. In extreme conditions, as with all semiconductors, this may include potentially hazardous rupture, a large current to flow or high voltage arcing, resulting in fire or explosion. Appropriate application design and safety precautions should always be followed to protect persons and property.

Product Status & Product Ordering:

We annotate datasheets in the top right hand corner of the front page, to indicate product status if it is not yet fully approved for production. The annotations are as follows:-

Target Information:	This is the most tentative form of information and represents a very preliminary specification. No actual design work on the product has been started.
Preliminary Information:	The product design is complete and final characterisation for volume production is in progress. The datasheet represents the product as it is now understood but details may change.
No Annotation:	The product has been approved for production and unless otherwise notified by Dynex any product ordered will be supplied to the current version of the data sheet prevailing at the time of our order acknowledgement.

All products and materials are sold and services provided subject to Dynex's conditions of sale, which are available on request.

Any brand names and product names used in this publication are trademarks, registered trademarks or trade names of their respective owners.

HEADQUARTERS OPERATIONS

DYNEX SEMICONDUCTOR LIMITED
Doddington Road, Lincoln, Lincolnshire, LN6 3LF
United Kingdom.
Phone: +44 (0) 1522 500500
Fax: +44 (0) 1522 500550
Web: <http://www.dynexsemi.com>

CUSTOMER SERVICE

Phone: +44 (0) 1522 502753 / 502901
Fax: +44 (0) 1522 500020
e-mail: power_solutions@dynexsemi.com